

LYSISTRATA JONES

BY LEWIS FLINN & DOUGLAS CARTER BEANE
PRODUCED BY ALLAN WASSER

DIRECTED BY DAN KNECHTGES
SET DESIGN BY ALLEN MOYER
COSTUME DESIGN BY DAVID WOOLARD &
THOMAS CHARLES LEGALLEY
LIGHTING DESIGN BY MICHAEL GOTTLIEB

THE WALTER KERR THEATER

SEPTEMBER 6, 2011

PLATE SCHEDULE - BOLDED PLATES HAVE REVISIONS AS OF SEPTEMBER 6, 2011

PLATE 01: GROUNDPLAN
PLATE 02: CL SECTION
PLATE 03: DECK PLAN
PLATE 04: SHOW PORTAL
PLATE 05: SR WALL (R&R FOR SL WALL)
PLATE 06: DS & US HEADERS
PLATE 07: BAND PLATFORM
PLATE 08: SR & SL LEGS & BASKETBALL BACKBOARDS
[PLATE 09: LED STRIPS] PLATE TO BE REVISED.
PLATE 10: LOCKER UNIT
PLATE 11: SHOW CURTAIN (SCRIM), BLACKOUT CURTAIN, MOON LIGHTBOX & KABUKI CURTAIN
PLATE 12: FLOWN EROS SIGN
PLATE 13: FLOWN BEADED CURTAIN
PLATE 14: TRACKED GYM CURTAIN
PLATE 15: TRACKED BROTHEL CURTAIN
PLATE 16: BACCHANAL CURTAIN AND LIGHTBULB UNIT
PLATE 17: LIGHT WALL & SCRIM, BORDER
PLATE 18: TRACKED CHARIOT

REVISION SCHEDULE SEPTEMBER 28
PLATE 01: DOORS MOVED TO OFFSTAGE SIDE OF SR AND SL WALLS
CROSS STAGE TRACK ADDED FOR CHARIOT
UPSTAGE TROUGH CUT

SEPTEMBER 6
PLATE 01: BASKETBALL BOARD CHANGES UPDATED. NEW LOCATIONS OF TRACKED UNITS UPDATED. UPSTAGE LIGHT WALL CHANGES UPDATED. LIGHTING POSITION INSIDE SR & SL WALL CHANGES UPDATED.
PLATE 02: BASKETBALL BOARD CHANGES UPDATED. LOCATIONS OF FLOWN SCENERY UPDATED. HEIGHT OF SL WALL & HEADERS UPDATED. LOCATIONS OF TRACKED SCENERY UPDATED. LIGHT WALL CHANGES UPDATED.
PLATE 04: SHOW PORTAL IS NOW PARTIALLY FRAMED SOFT GOODS.
PLATE 05: SR WALL IS NOW OF VARYING HEIGHTS. VENTS ARE LARGER, WITH NEW SPECS. BASKETBALL BOARDS UPDATED.
PLATE 06: BEAMS RENAMED HEADERS FOR CLARITY. HEADERS ARE NOW VARYING HEIGHTS.
PLATE 07: TRACK POSITIONS HAVE BEEN UPDATED.
PLATE 08: LEGS ARE NOW SOFT. BASKETBALL BACKBOARDS ARE NO LONGER LIGHTBOXES.
PLATE 10: LX HAS BEEN STRIPPED FROM UNIT.
PLATE 12: PLAN HAS BEEN CORRECTED TO ACCURATELY REFLECT UNIT.
PLATE 13: TRACKED BEADED CURTAIN HAS BEEN CUT, FLOWN BEADED CURTAIN HAS BEEN LENGTHENED AND ITS WIDTH HAS SHORTENED.
PLATE 14: REVISED SPECS AND WIDTH, PLAYING POSITION UPDATED.
PLATE 15: PLAYING POSITION UPDATED.
PLATE 16: LIGHTBOX HAS BEEN CUT. LX ADDED TO OUTSIDE OF LETTER FRAMES.
PLATE 17: LIGHTWALL TRACKING HAS BEEN CUT AND DESIGN UPDATED. SCRIM ADDED. BORDER DRAWING ADDED.

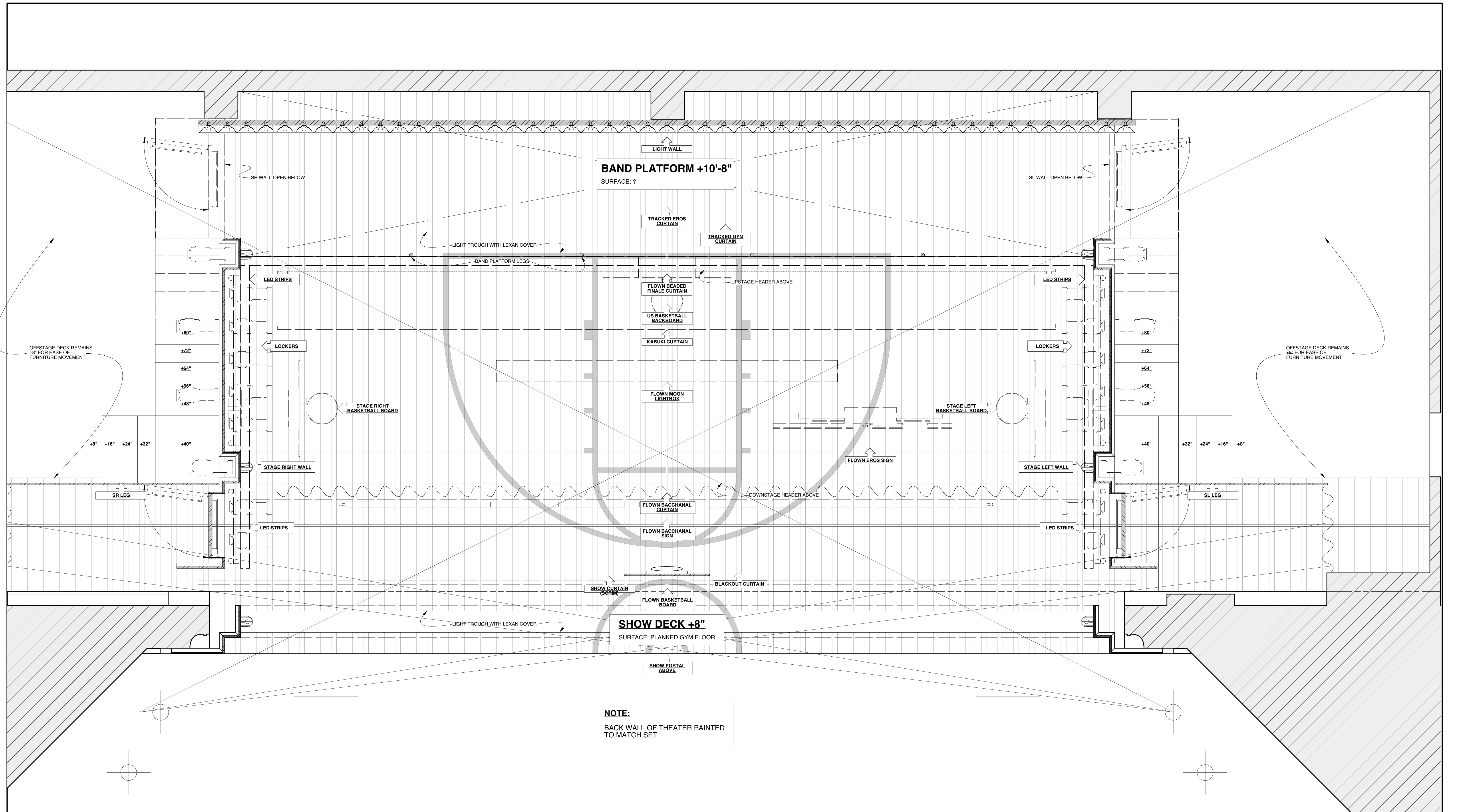

NOTE:
 BACK WALL OF THEATER PAINTED
 TO MATCH SET.

<p>S.D. 3347 SCENIC DESIGNER</p>	<p>GROUNDPLAN LYSISTRATA JONES by LEWIS FLINN & DOUGLAS CARTER BEANE</p>	<p>SHEET 1</p>
	<p>WALTER KERR THEATER DIRECTED BY DAN KNECHTGES</p>	
	<p>DESIGN BY ALLEN MOYER</p>	<p>DATE: OCTOBER 10, 2011</p>
	<p>SCALE: 1/2" = 1'-0"</p>	
	<p>SIGNATURE _____</p>	

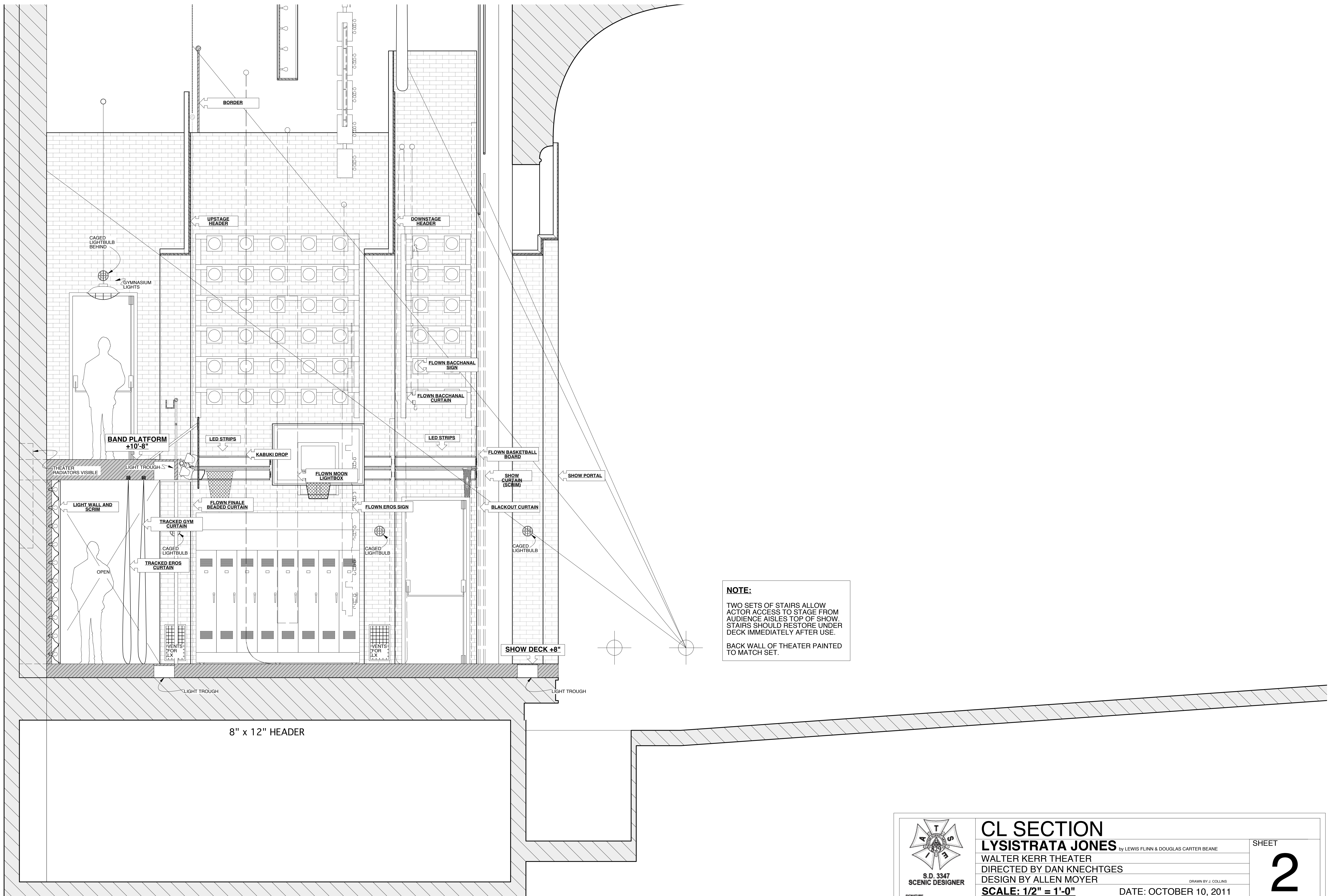

NOTE:
 TWO SETS OF STAIRS ALLOW ACTOR ACCESS TO STAGE FROM AUDIENCE AISLES TOP OF SHOW. STAIRS SHOULD RESTORE UNDER DECK IMMEDIATELY AFTER USE.
 BACK WALL OF THEATER PAINTED TO MATCH SET.

8" x 12" HEADER

<p>S.D. 3347 SCENIC DESIGNER</p>	CL SECTION	SHEET
	LYSISTRATA JONES <small>by LEWIS FLINN & DOUGLAS CARTER BEANE</small>	
	WALTER KERR THEATER	
	DIRECTED BY DAN KNECHTGES	
	DESIGN BY ALLEN MOYER	
SCALE: 1/2" = 1'-0"	DATE: OCTOBER 10, 2011	2

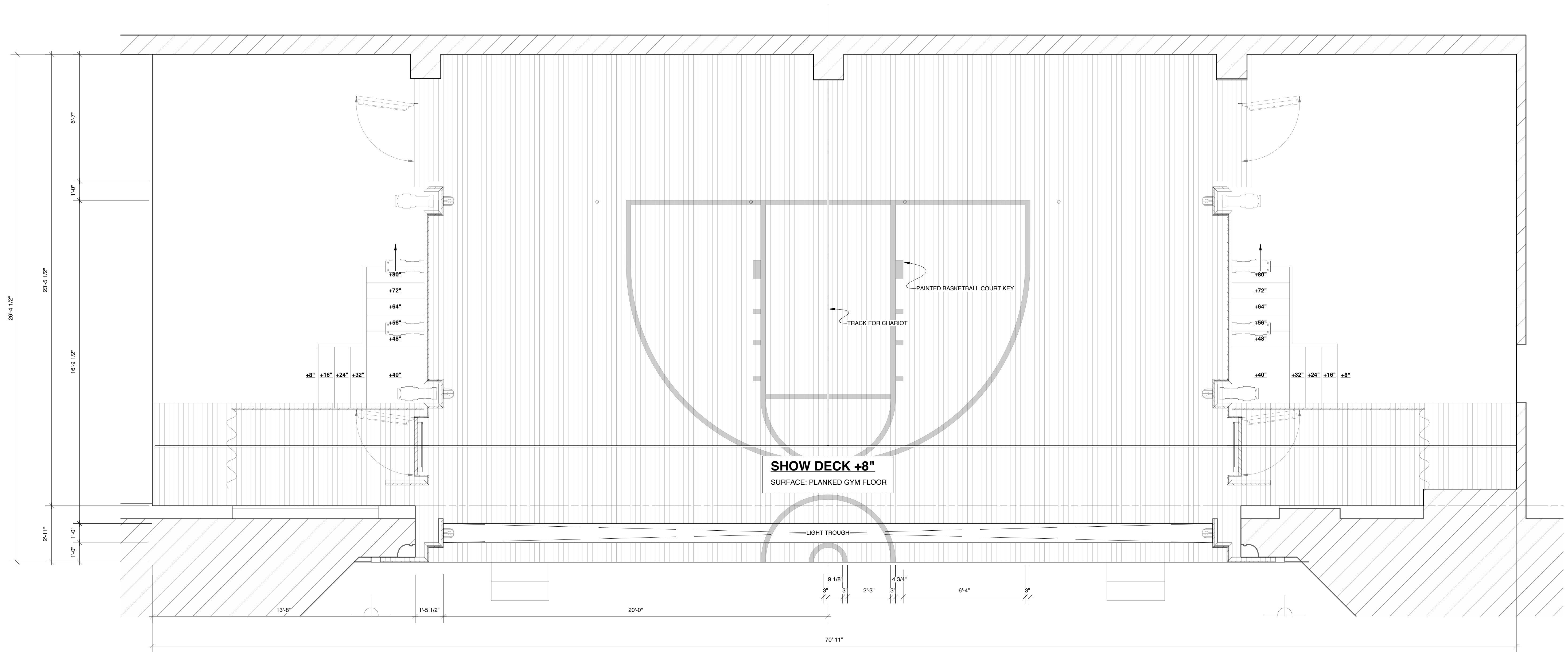

<p>S.D. 3347 SCENIC DESIGNER</p>	DECK PLAN	SHEET
	LYSISTRATA JONES <small>by LEWIS FLINN & DOUGLAS CARTER BEANE</small>	
	WALTER KERR THEATER	
	DIRECTED BY DAN KNECHTGES	
	DESIGN BY ALLEN MOYER	
<small>SIGNATURE</small> _____	SCALE: 3/8" = 1'-0"	DATE: OCTOBER 10, 2011
		3

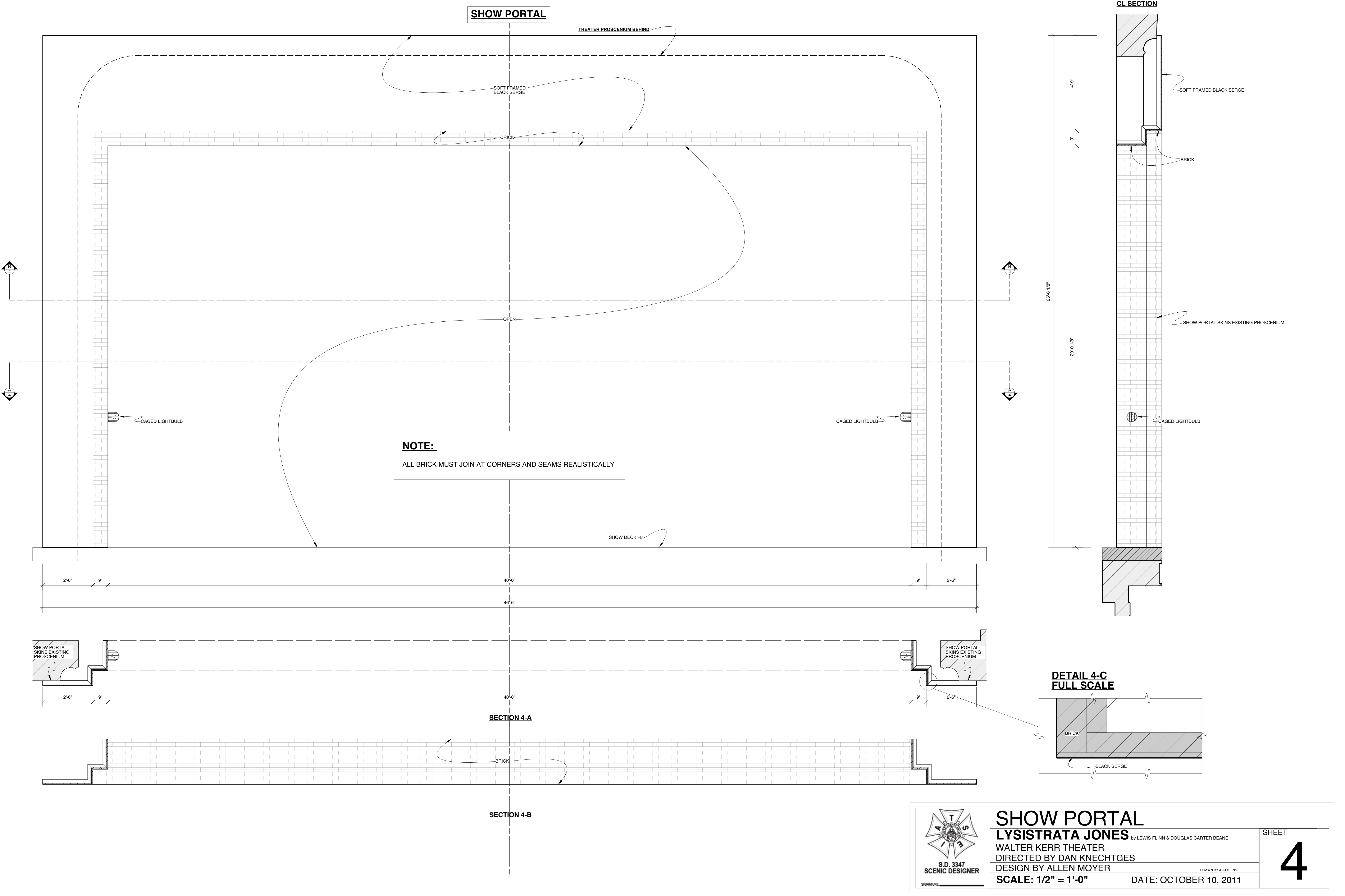

SHOW PORTAL

THEATER PROSCENIUM BEHIND

SOFT FRAMED BLACK SERGE

BRICK

OPEN

NOTE:
ALL BRICK MUST JOIN AT CORNERS AND SEAMS REALISTICALLY

SHOW DECK +8"

CAGED LIGHTBULB

CAGED LIGHTBULB

CL SECTION

SOFT FRAMED BLACK SERGE

BRICK

SHOW PORTAL SKINS EXISTING PROSCENIUM

CAGED LIGHTBULB

2'-6" 9" 40'-0" 9" 2'-6"

46'-6"

2'-6" 9" 40'-0" 9" 2'-6"

SECTION 4-A

SECTION 4-B

BRICK

DETAIL 4-C FULL SCALE

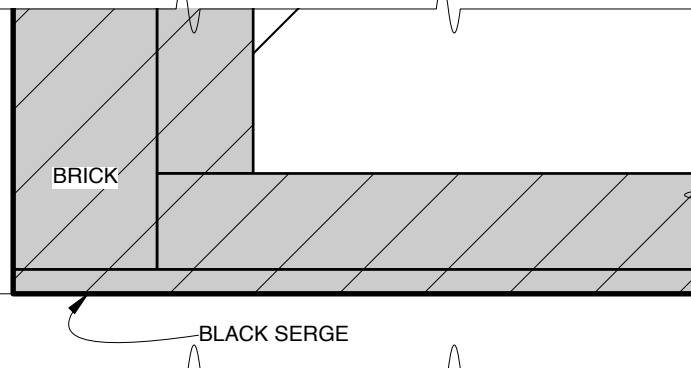

SHOW PORTAL
LYSISTRATA JONES

by LEWIS FLINN & DOUGLAS CARTER BEANE
WALTER KERR THEATER
DIRECTED BY DAN KNECHTGES
DESIGN BY ALLEN MOYER
SCALE: 1/2" = 1'-0"

DATE: OCTOBER 10, 2011

SHEET

4

SR WALL (R&R FOR SL WALL)

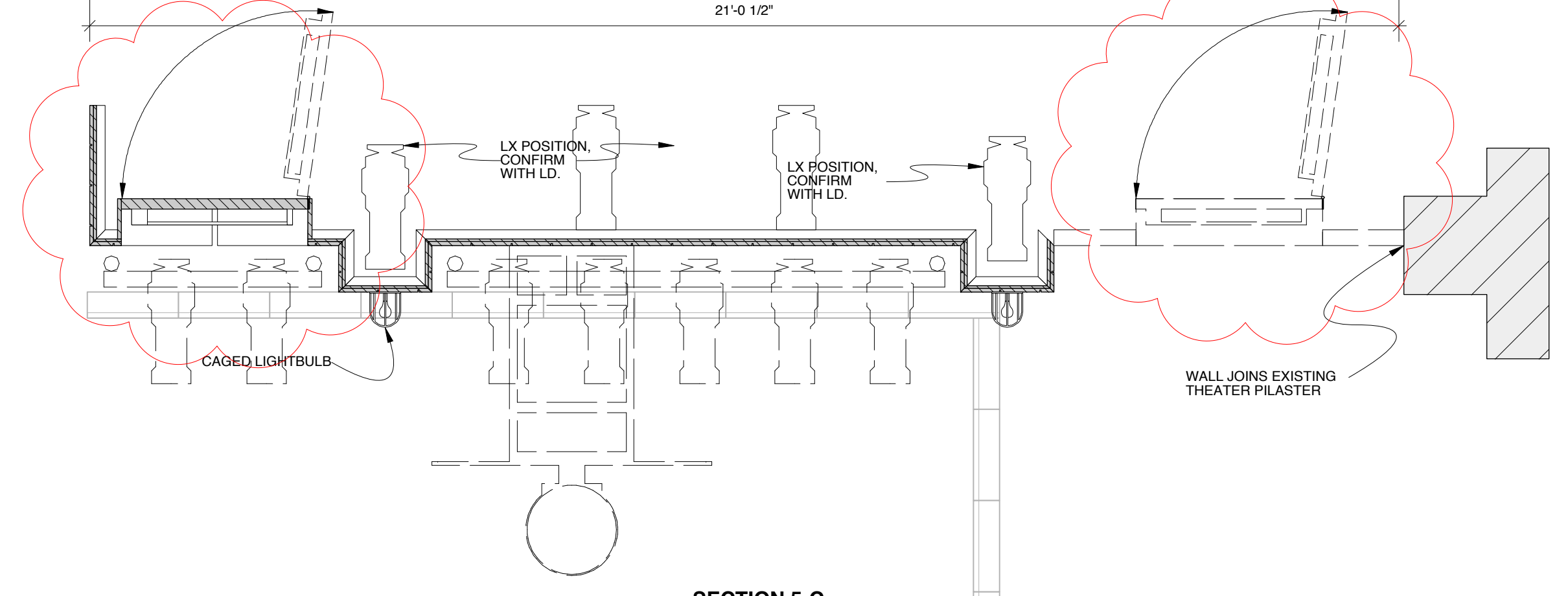
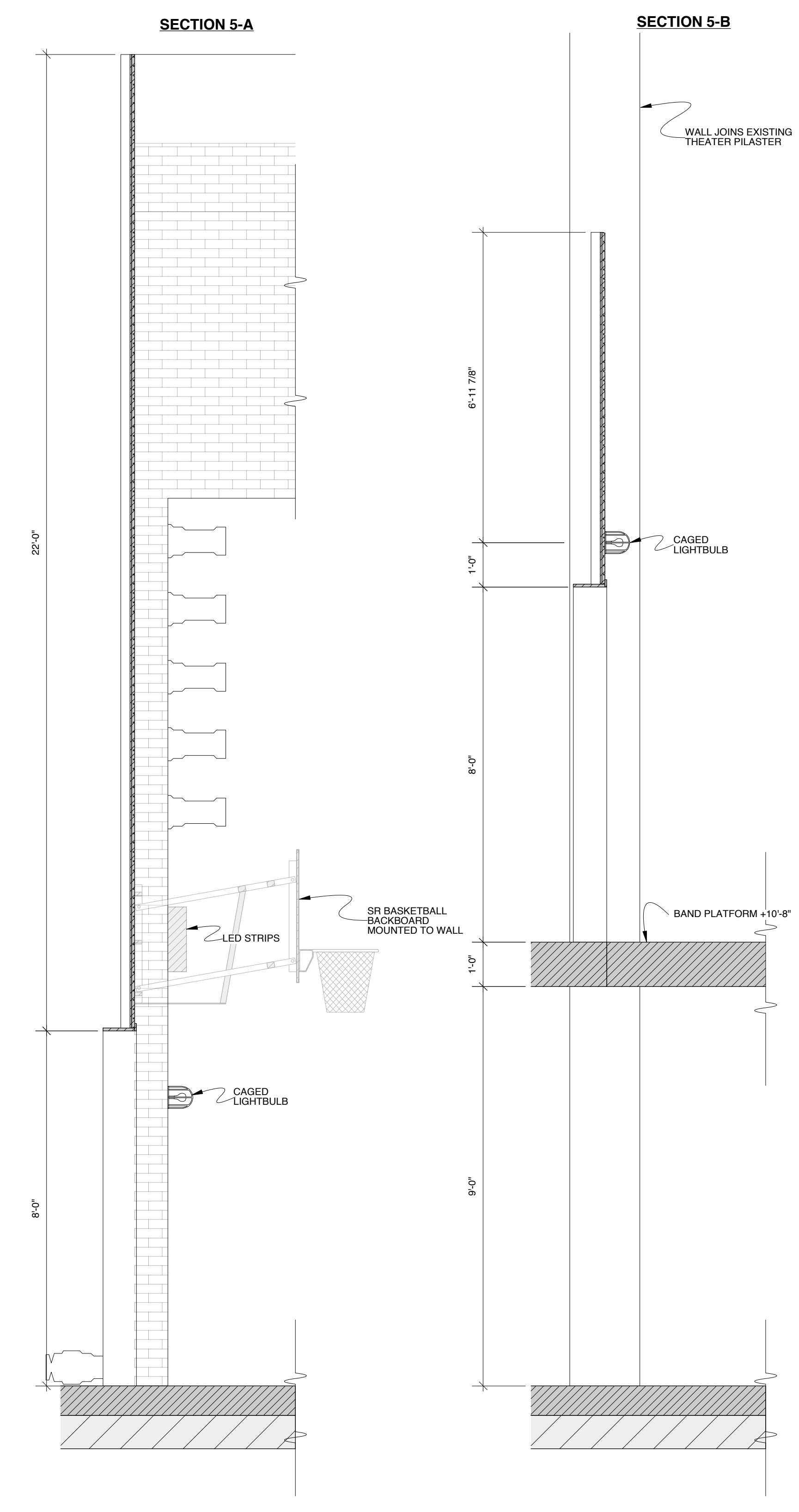
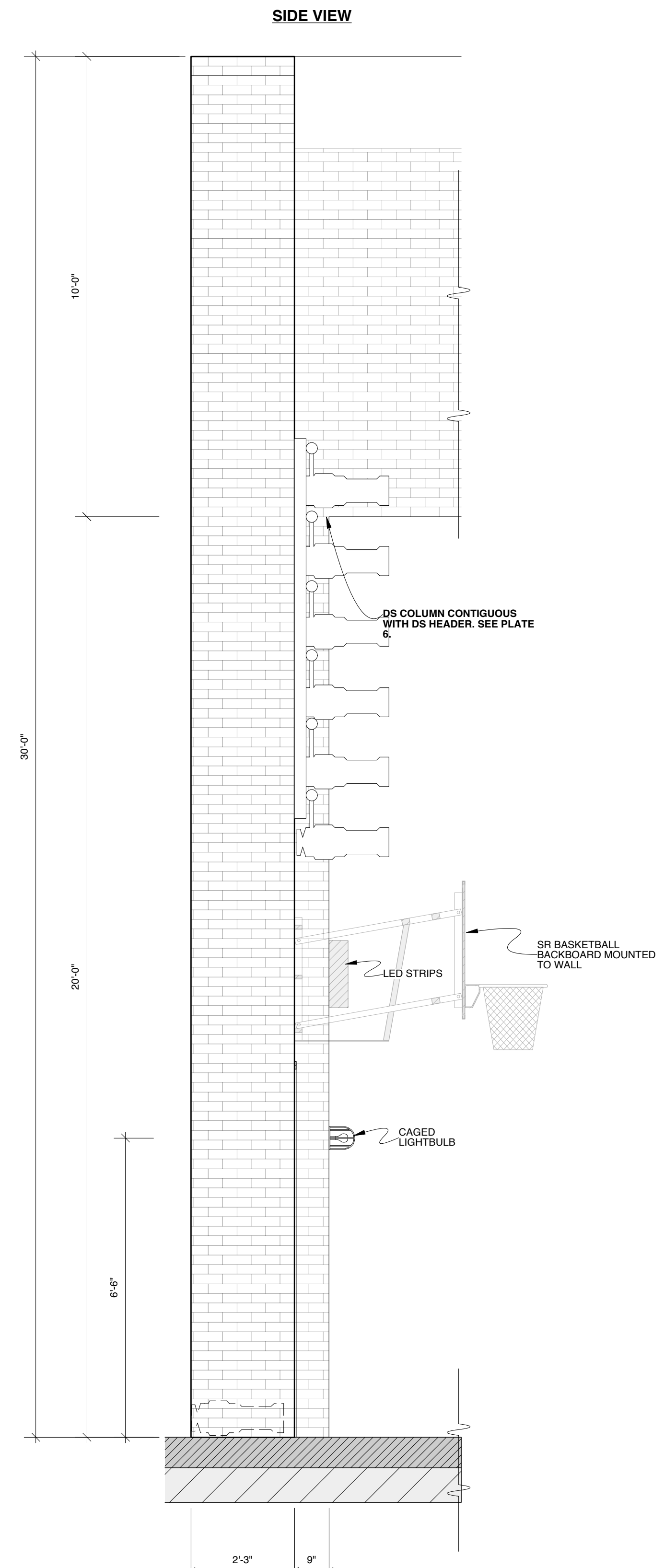
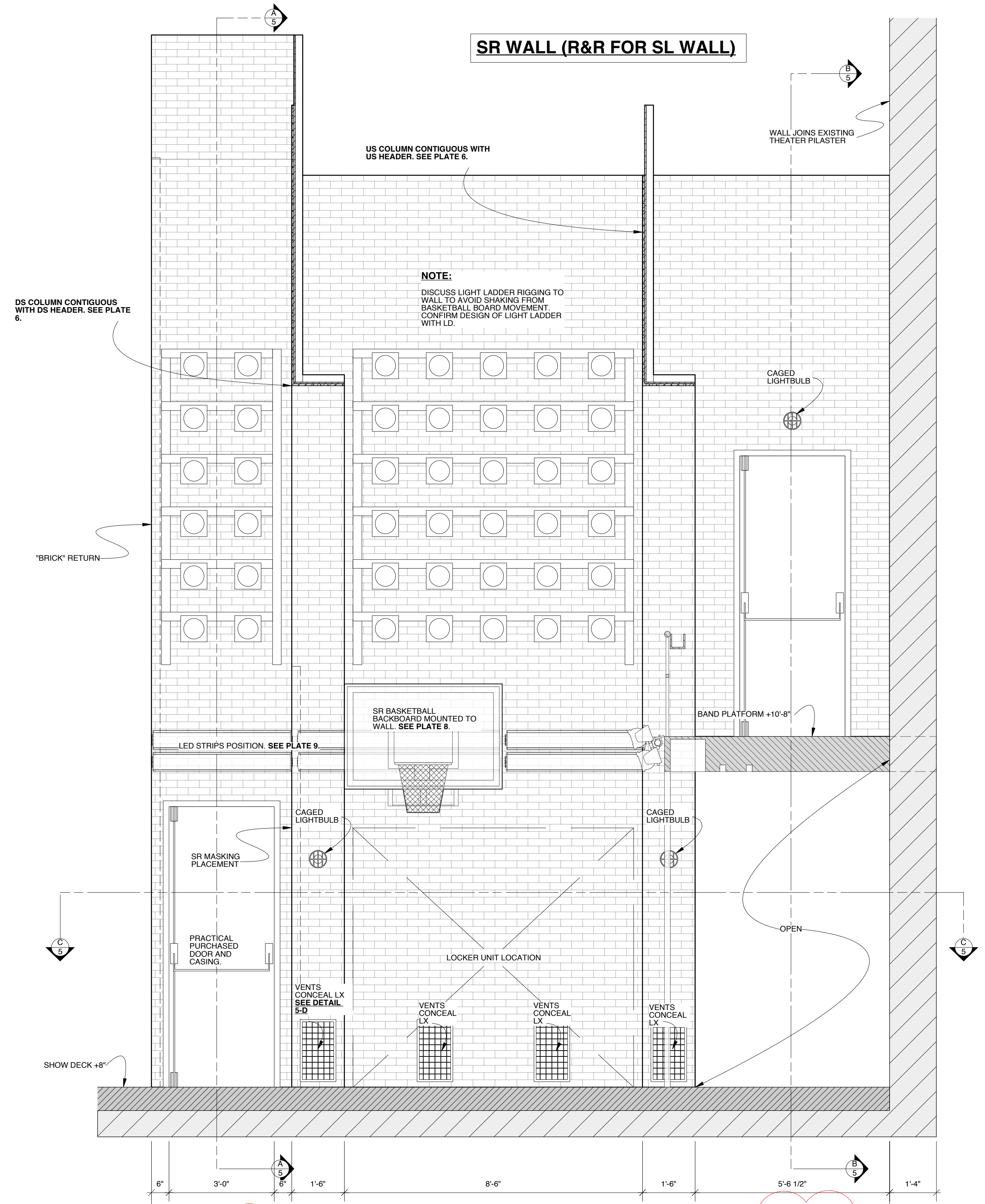

DETAIL 5-D
SCALE: 1 1/2" = 1'-0"

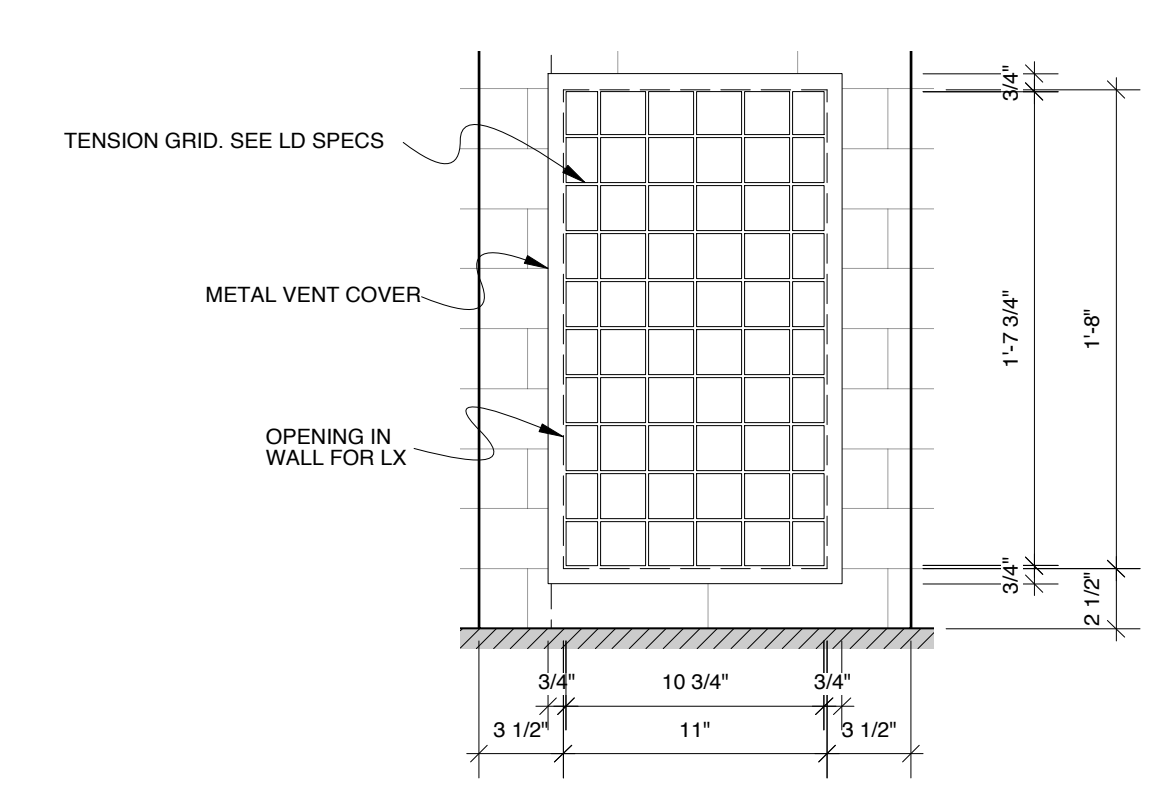

NOTE:
ALL BRICK MUST JOIN AT CORNERS AND SEAMS REALISTICALLY

<p>S.D. 3347 SCENIC DESIGNER</p>	<p>SR WALL (R&R FOR SL WALL) LYSISTRATA JONES by LEWIS FLINN & DOUGLAS CARTER BEANE</p>		<p>SHEET 5</p>
	<p>WALTER KERR THEATER DIRECTED BY DAN KNECHTGES DESIGN BY ALLEN MOYER</p>		
	<p>SCALE: 1/2" = 1'-0" DATE: OCTOBER 10, 2011</p>		
	<p>DRAWN BY J. COLLINS</p>		
	<p>SIGNATURE _____</p>		

DS HEADER

BLACK SERGE

41'-8"

SECTION 6-A

CAGED LIGHTBULB

CAGED LIGHTBULB

CENTERLINE SECTION

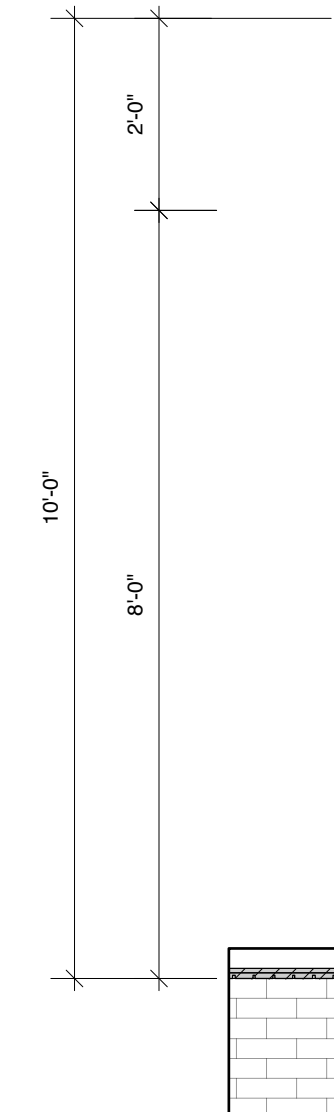

NOTE:

ALL BRICK MUST JOIN AT CORNERS AND SEAMS REALISTICALLY

US HEADER

BLACK SERGE

CENTERLINE SECTION

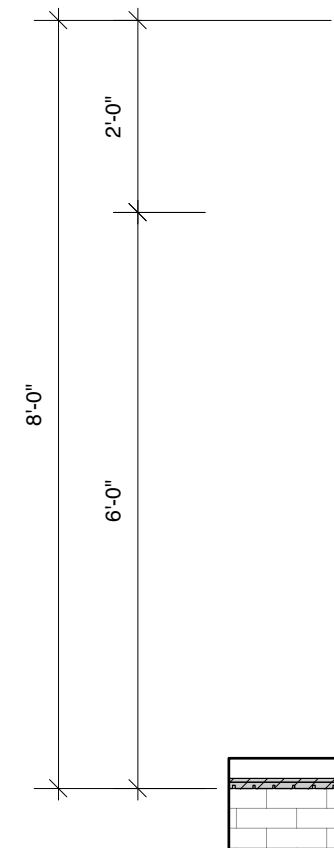

 <p>S.D. 3347 SCENIC DESIGNER</p>	DOWNSTAGE/UPSTAGE HEADERS		<p>SHEET</p> <h1>6</h1>
	LYSISTRATA JONES by LEWIS FLINN & DOUGLAS CARTER BEANE		
	WALTER KERR THEATER		
	DIRECTED BY DAN KNECHTGES		
	DESIGN BY ALLEN MOYER		
SCALE: 1/2" = 1'-0"	DATE: OCTOBER 10, 2011		

BAND PLATFORM

SECTION 9-A

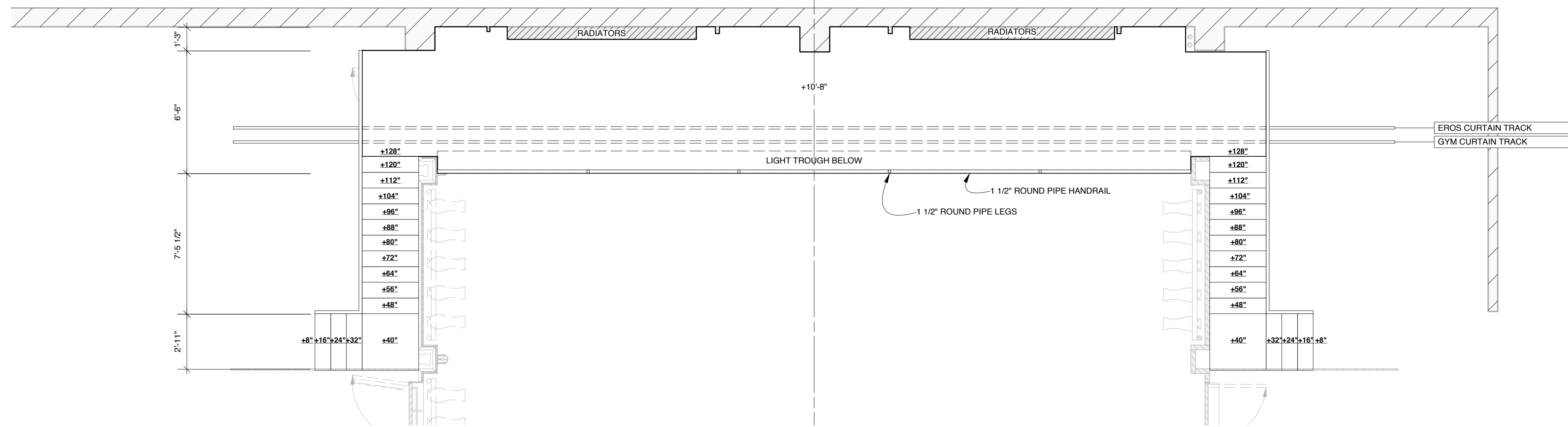
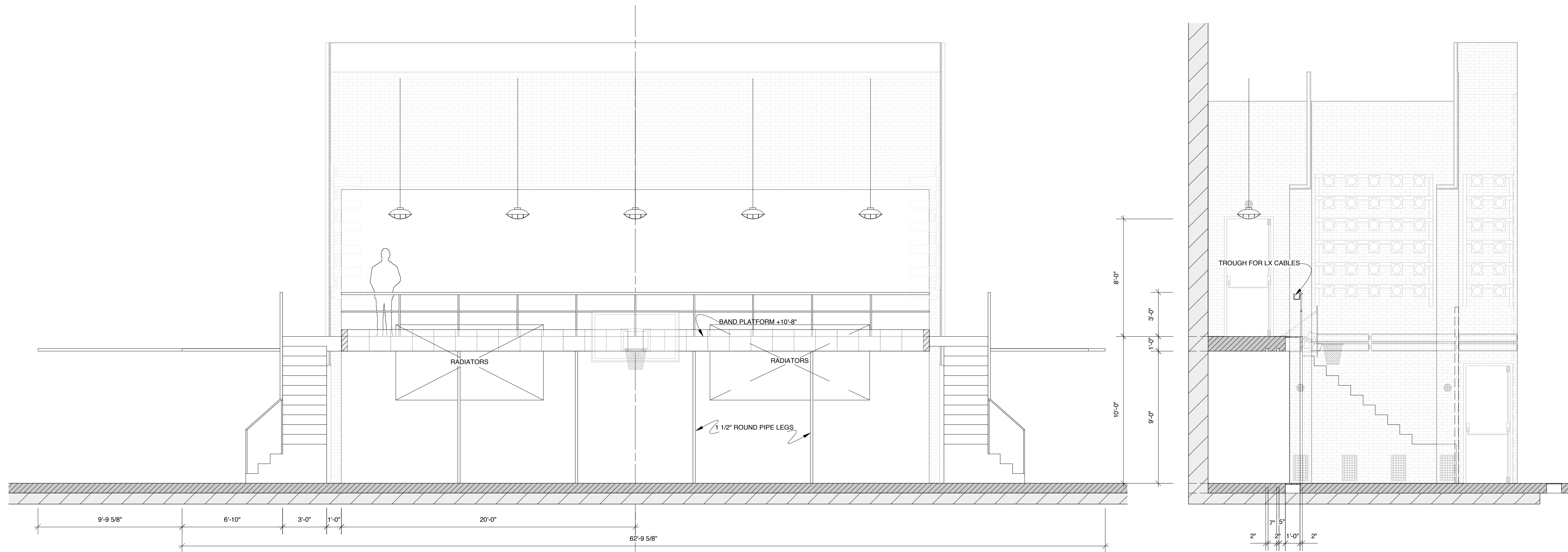

PLAN VIEW

<p>S.D. 3347 SCENIC DESIGNER</p>	<p>BAND PLATFORM LYSISTRATA JONES</p>	<p>SHEET</p>	
	<p>by LEWIS FLINN & DOUGLAS CARTER BEANE</p>	<p style="font-size: 2em; font-weight: bold;">7</p>	
	<p>WALTER KERR THEATER</p>		
	<p>DIRECTED BY DAN KNECHTGES</p>		
	<p>DESIGN BY ALLEN MOYER</p>		
<p>SCALE: 1/4" = 1'-0"</p>	<p>DATE: OCTOBER 10, 2011</p>		

SR LEG

SOFT GOOD
HUNG WITHOUT FULLNESS.

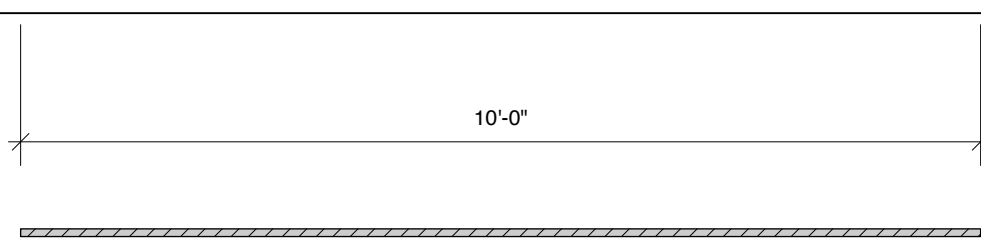
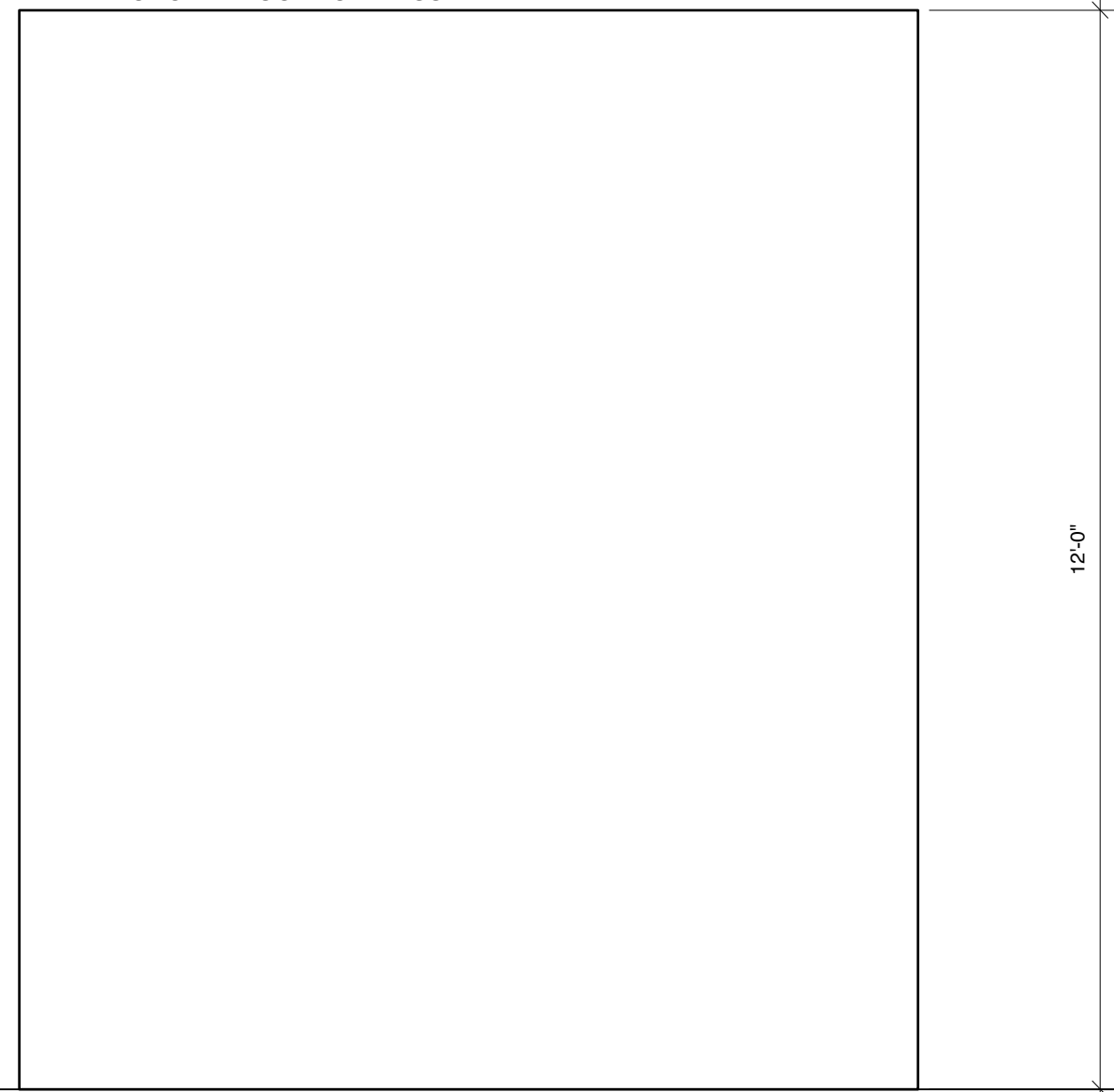

PLAN VIEW

SL LEG

SOFT GOOD
HUNG WITHOUT FULLNESS.

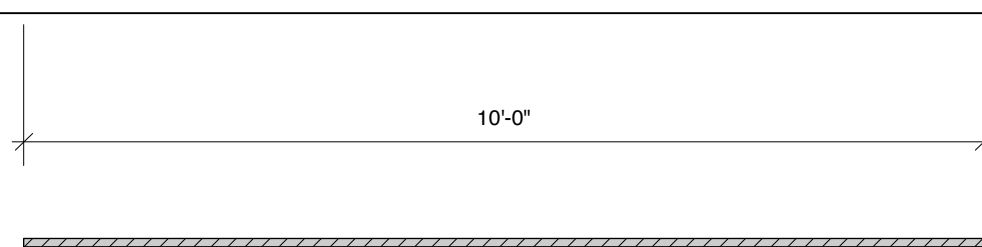
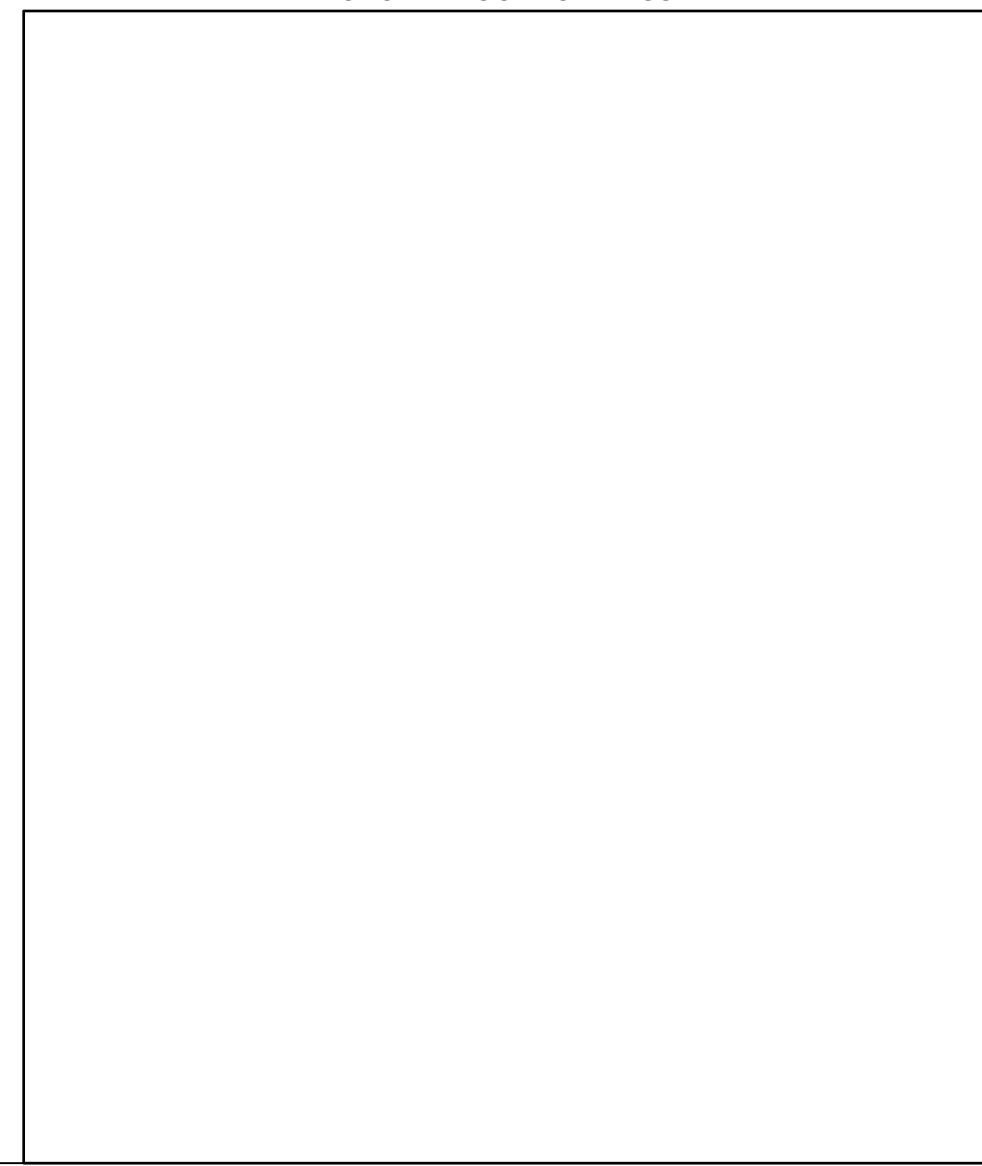

PLAN VIEW

RESEARCH



US BASKETBALL BOARD

BACKBOARD IS PURCHASED.
FRAME BACKED BY GREY RP MATERIAL.
BACKBOARD IS MOUNTED TO SR WALL AND MOUNTING HARDWARE MUST CLEAR LED STRIPS.
RIMS MUST SUPPORT 180lb ACTORS HANGING ON THEM.

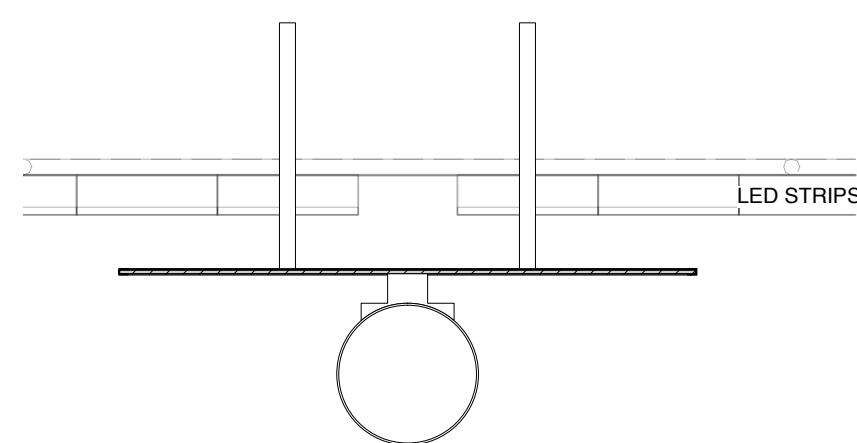
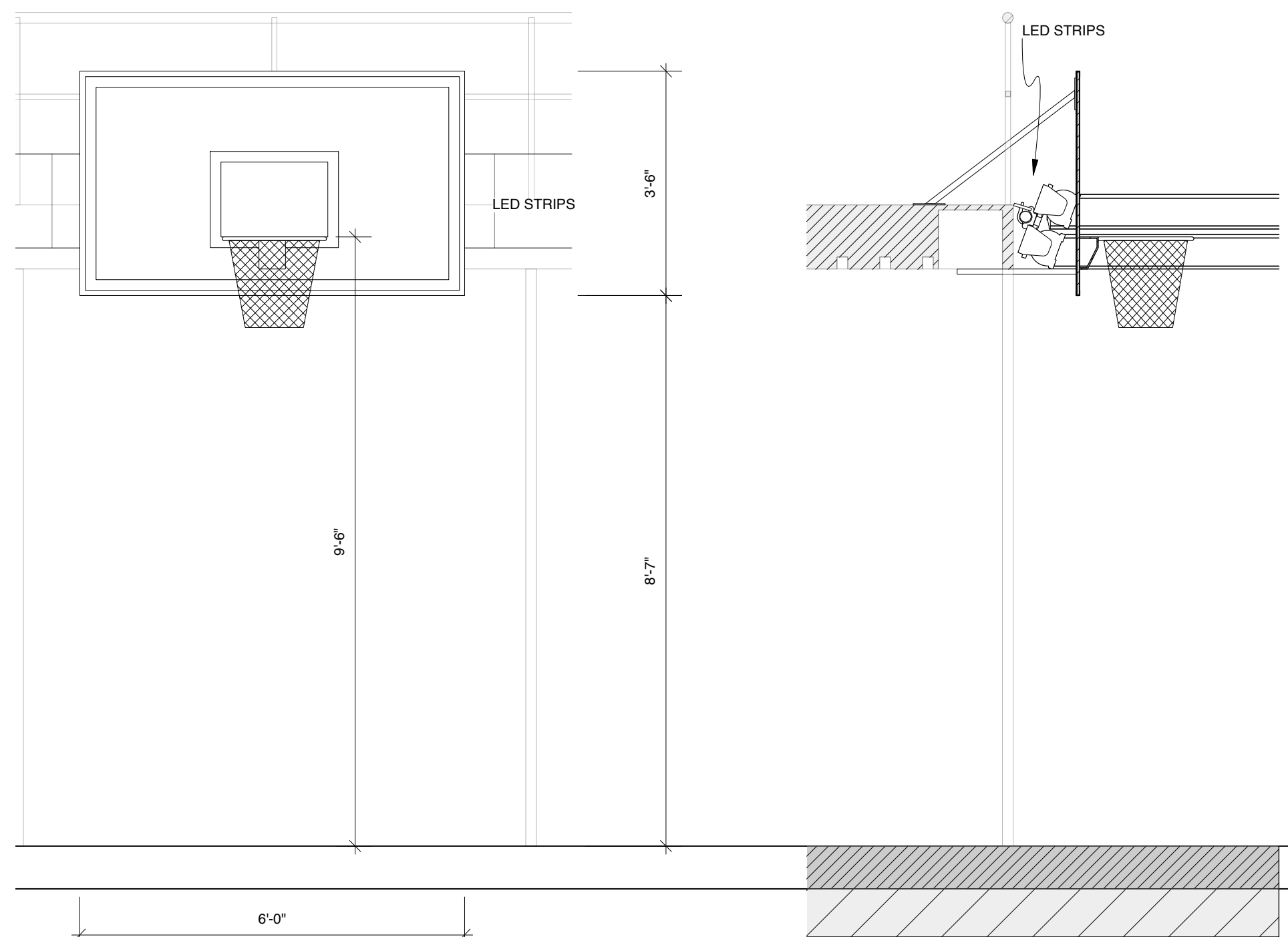

PLAN VIEW

SIDE BASKETBALL BOARDS - MAKE TWO

BACKBOARD IS PURCHASED.
FRAME BACKED BY GREY RP MATERIAL.
BACKBOARD IS MOUNTED TO SR WALL AND MOUNTING HARDWARE MUST CLEAR LED STRIPS.
SEE RESEARCH ABOVE RIGHT.
RIMS MUST SUPPORT 180lb ACTORS HANGING ON THEM.

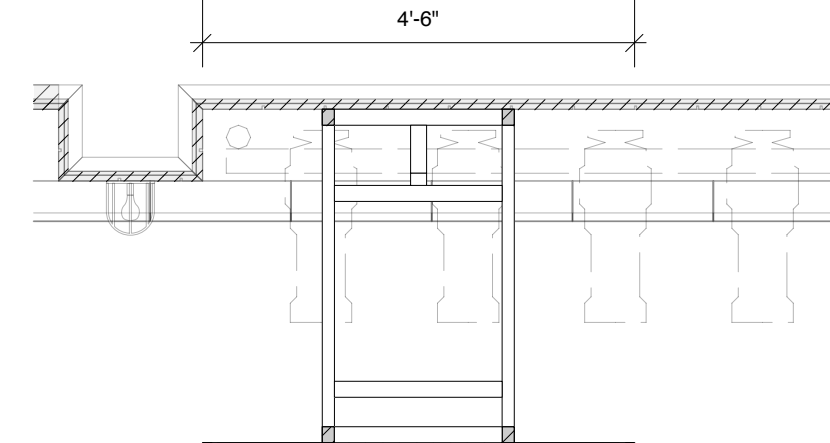
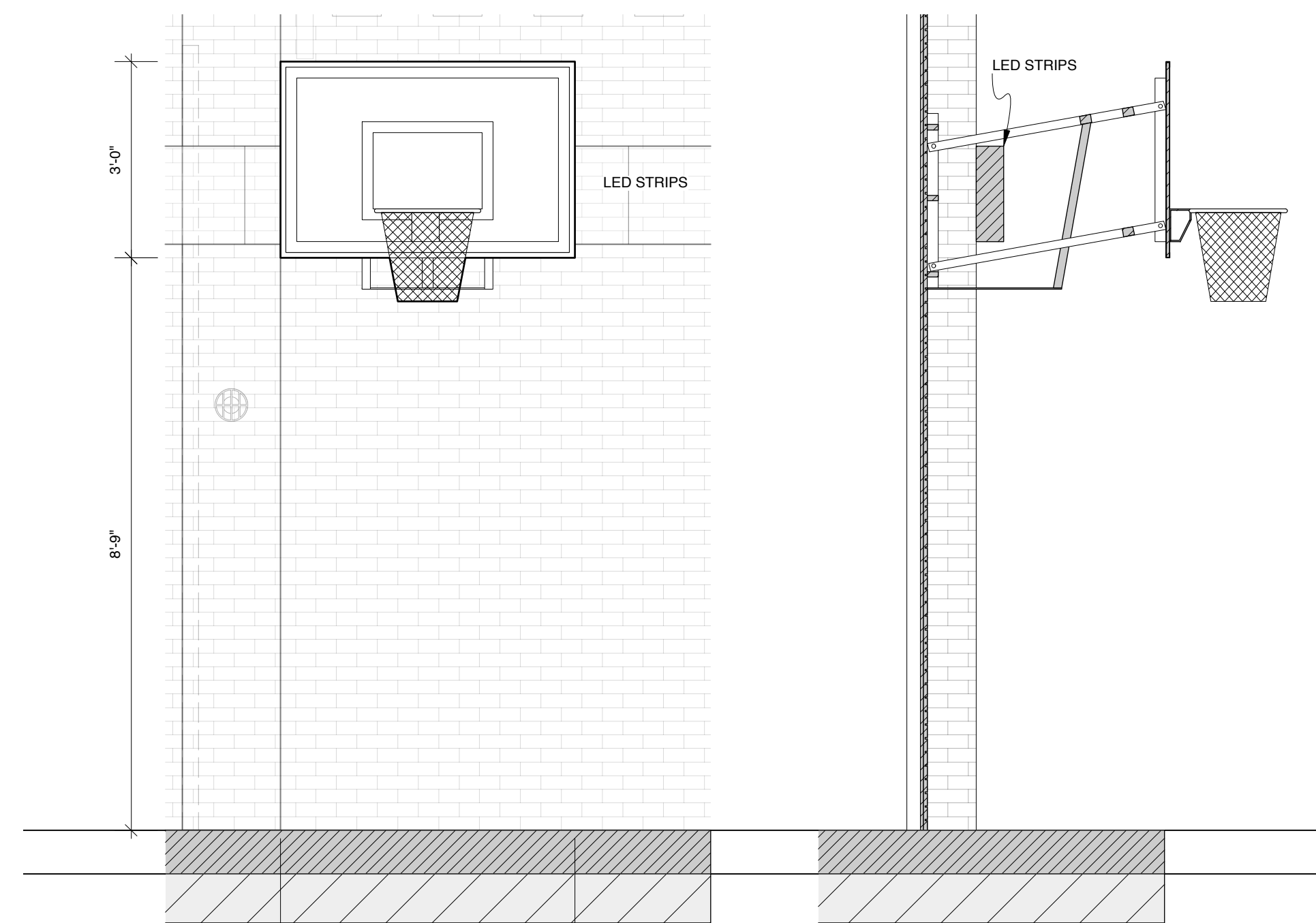

PLAN VIEW

FLOWN BASKETBALL BOARD

RIGGED TO FLY WITH STEEL BOX TUBE FOR STABILITY.
RIM FLIPS UP IN PLAYING POSITION AND RESTORES TO DOWN POSITION FOR STORAGE.

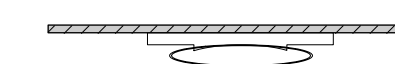
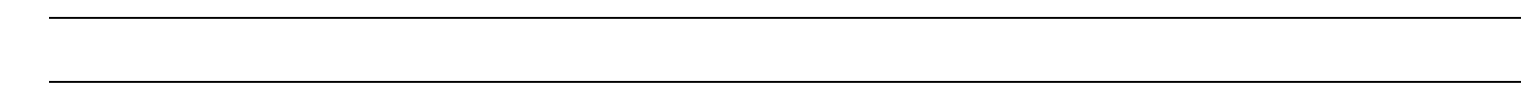
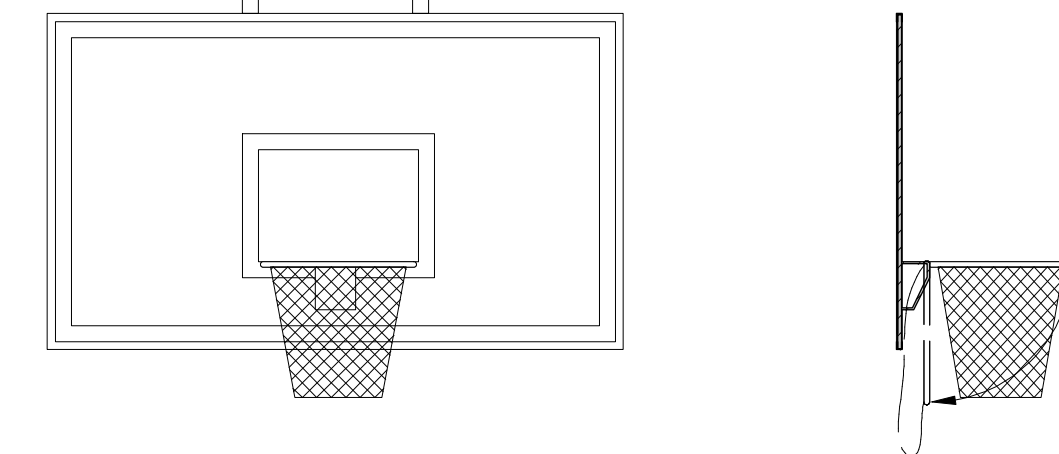

SR & SL LEGS, BASKETBALL BOARDS

LYSISTRATA JONES by LEWIS FLINN & DOUGLAS CARTER BEANE
WALTER KERR THEATER
DIRECTED BY DAN KNECHTGES
DESIGN BY ALLEN MOYER
SCALE: 1/2" = 1'-0" DATE: OCTOBER 10, 2011

SHEET

8

LED STRIPS

LED STRIPS IS A PURCHASED ELEMENT. SPECS TBD.
STRIPS FACED WITH 1/2" LEXAN.

DETAIL 9-A

HALF SCALE

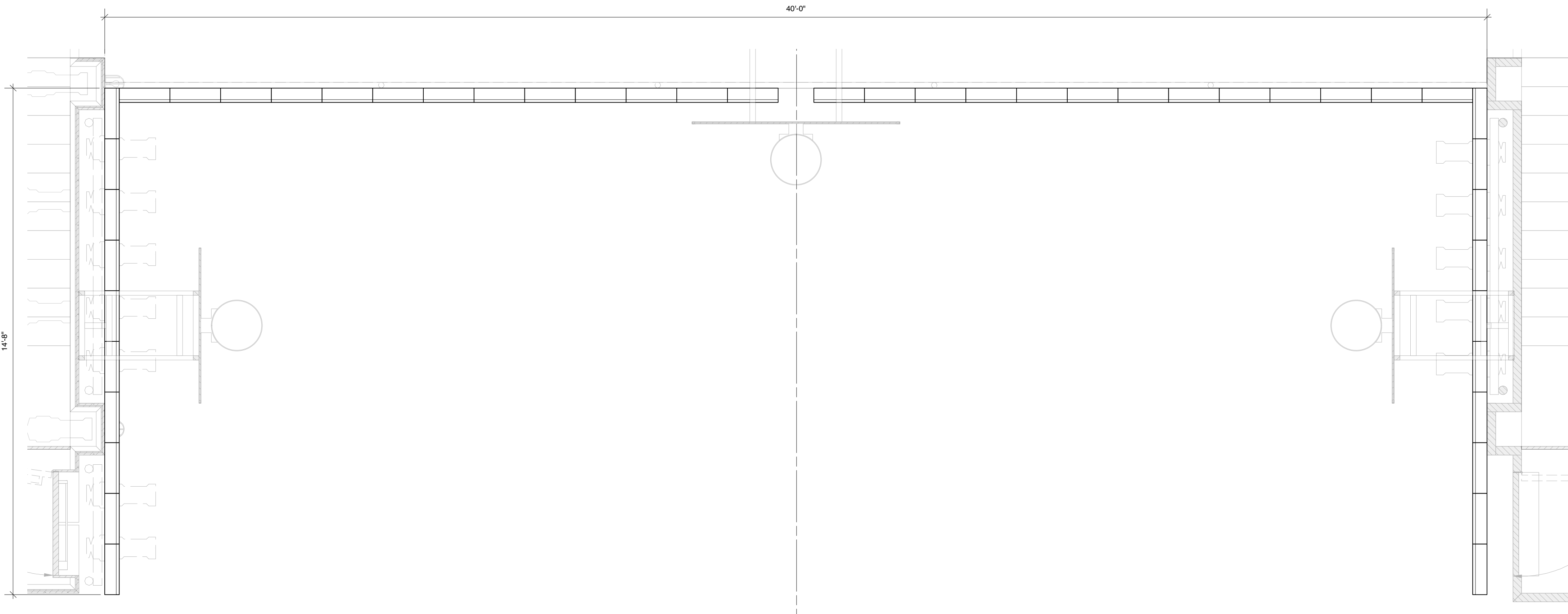
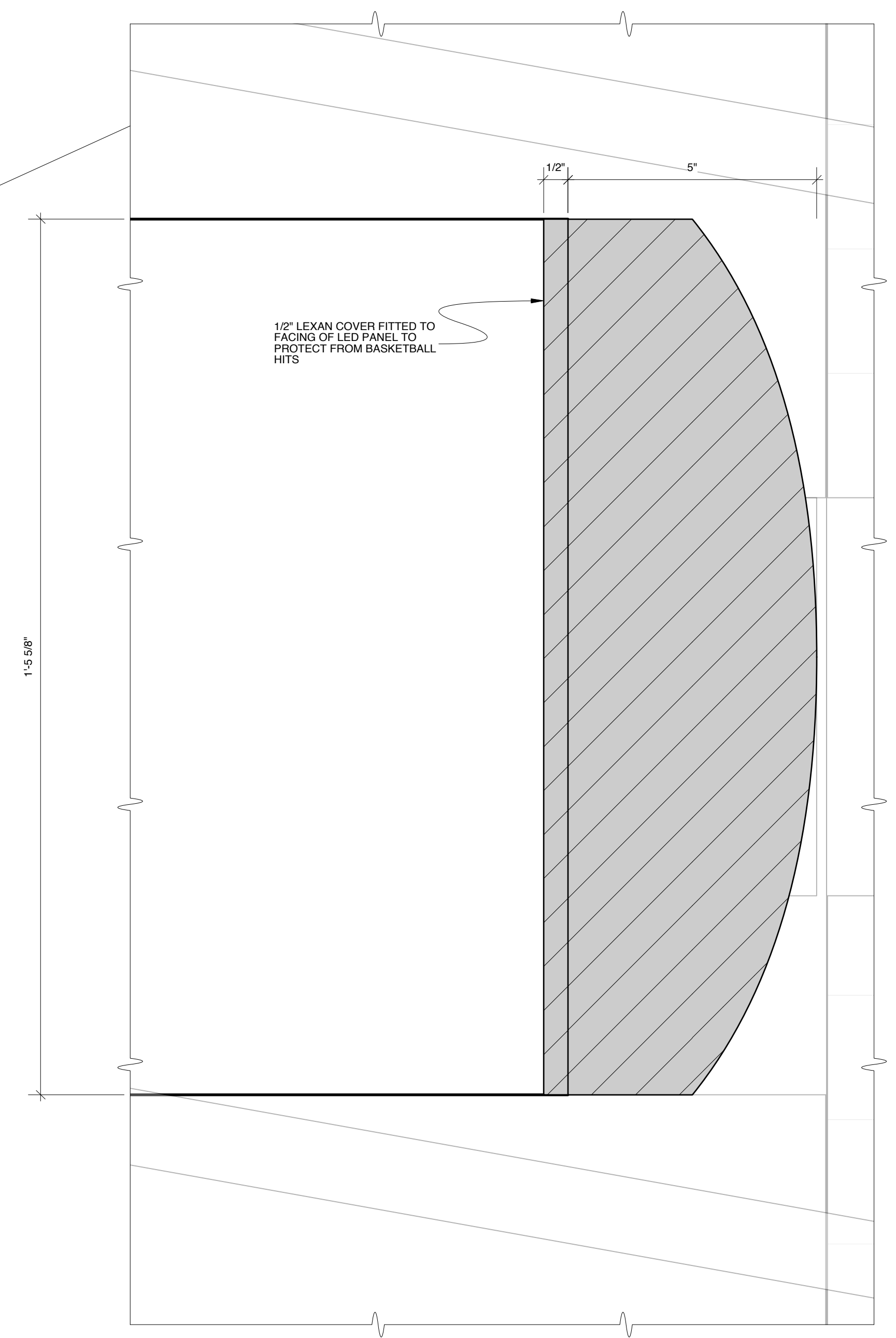
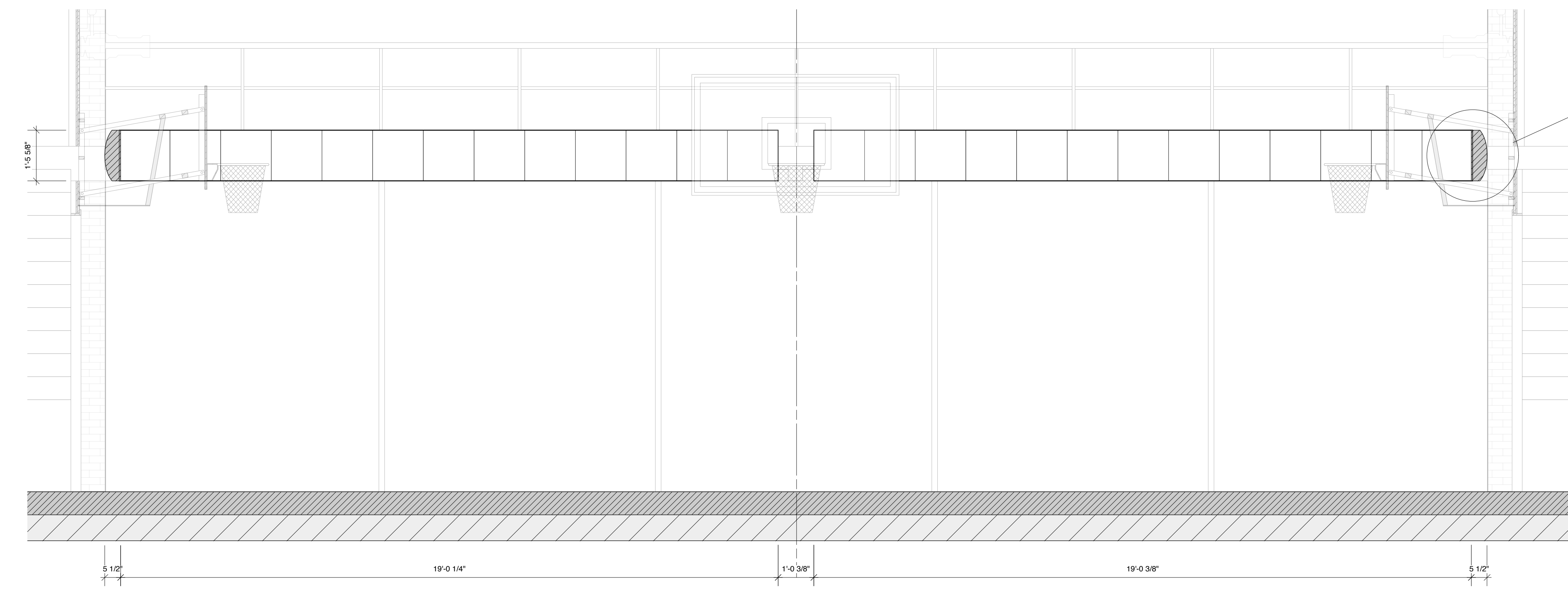

PLAN VIEW

<p>S.D. 3347 SCENIC DESIGNER</p>	LED STRIPS	SHEET 9
	LYSISTRATA JONES by LEWIS FLINN & DOUGLAS CARTER BEANE	
	WALTER KERR THEATER	
	DIRECTED BY DAN KNECHTGES	
	DESIGN BY ALLEN MOYER	
SCALE: 1/2" = 1'-0"	DATE: OCTOBER 10, 2011	

LOCKER UNIT: MAKE 2

UNITS ARE CASTERED.
UNITS HAVE FOOT BREAKS TBD.

SECTION 10-A

REAR VIEW

NOTE:

JE" IS BENJAMIN MOORE #812
ANGE" IS TO MATCH THE LOCKERS
ITE" SHOULD BE A PALE GREY

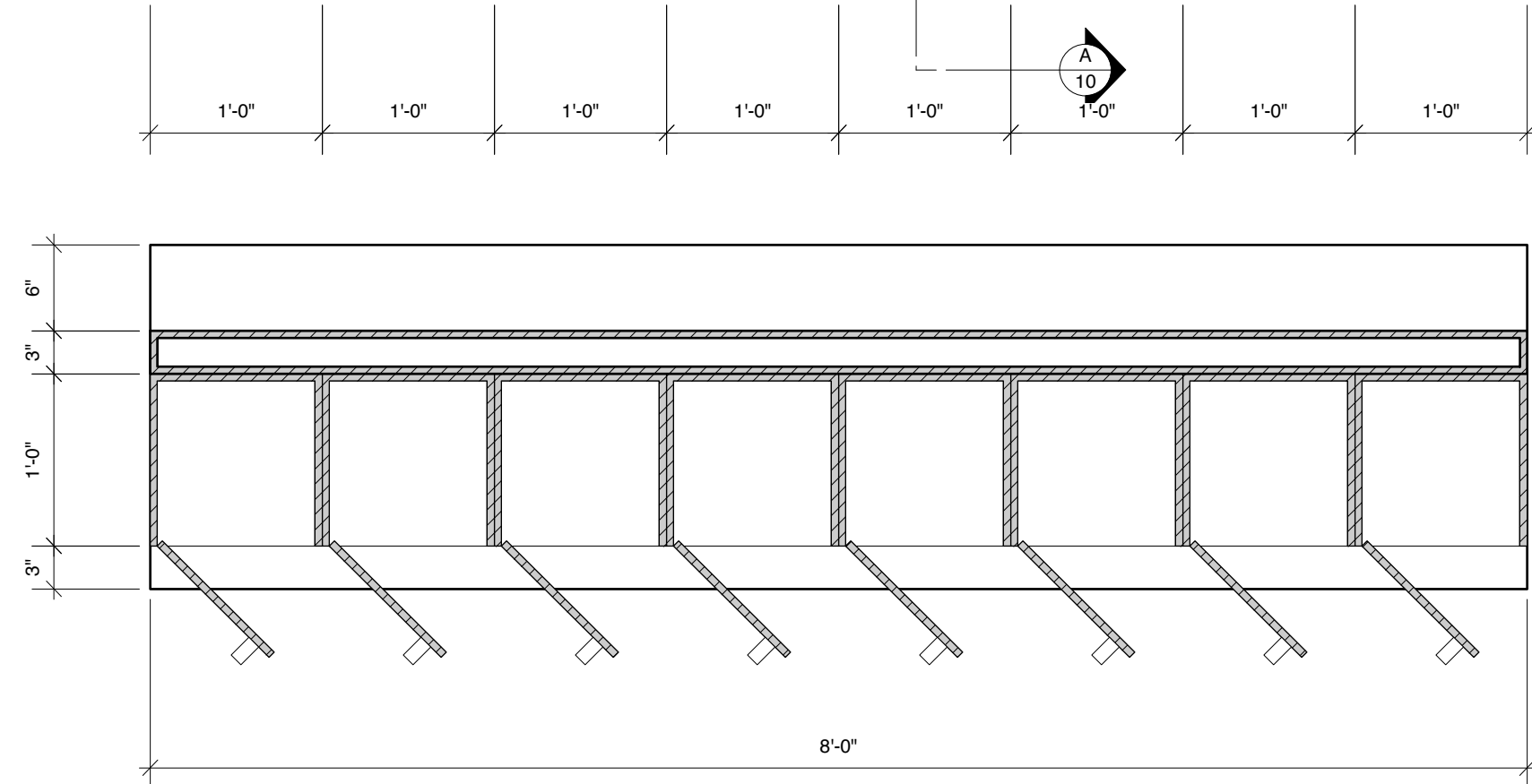
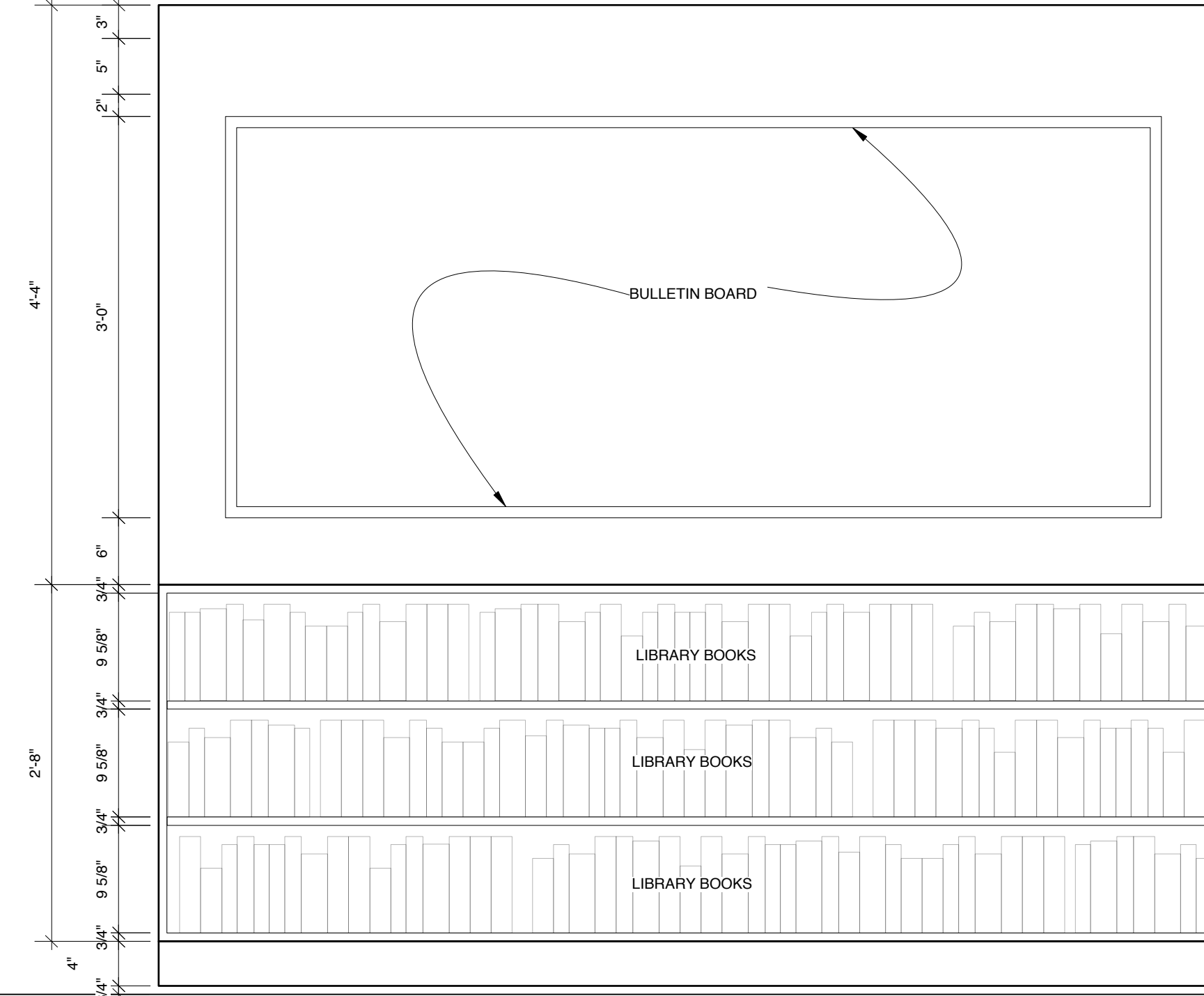
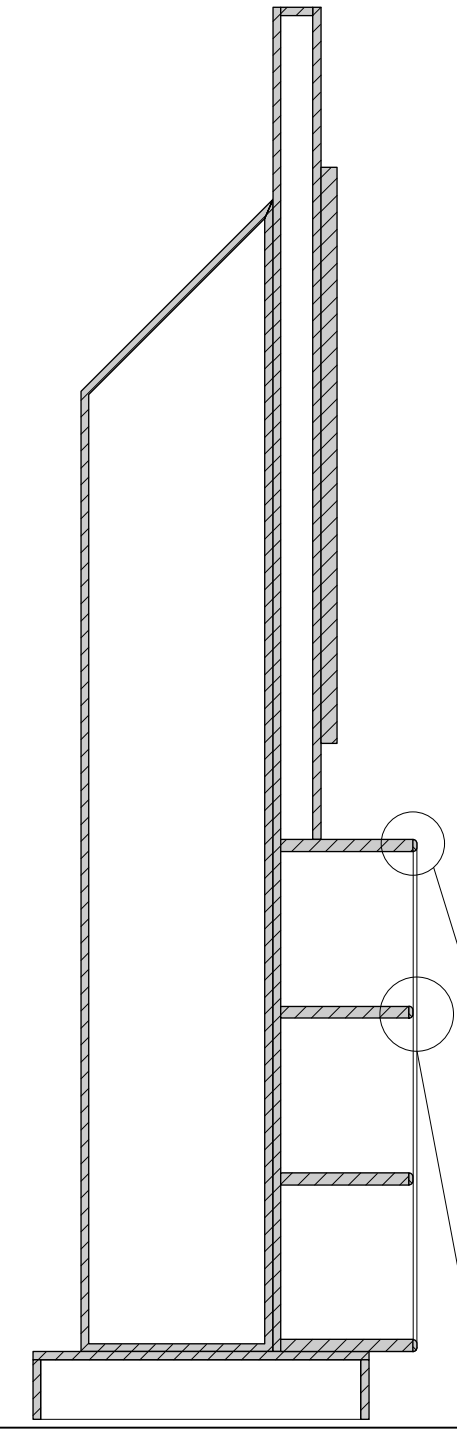
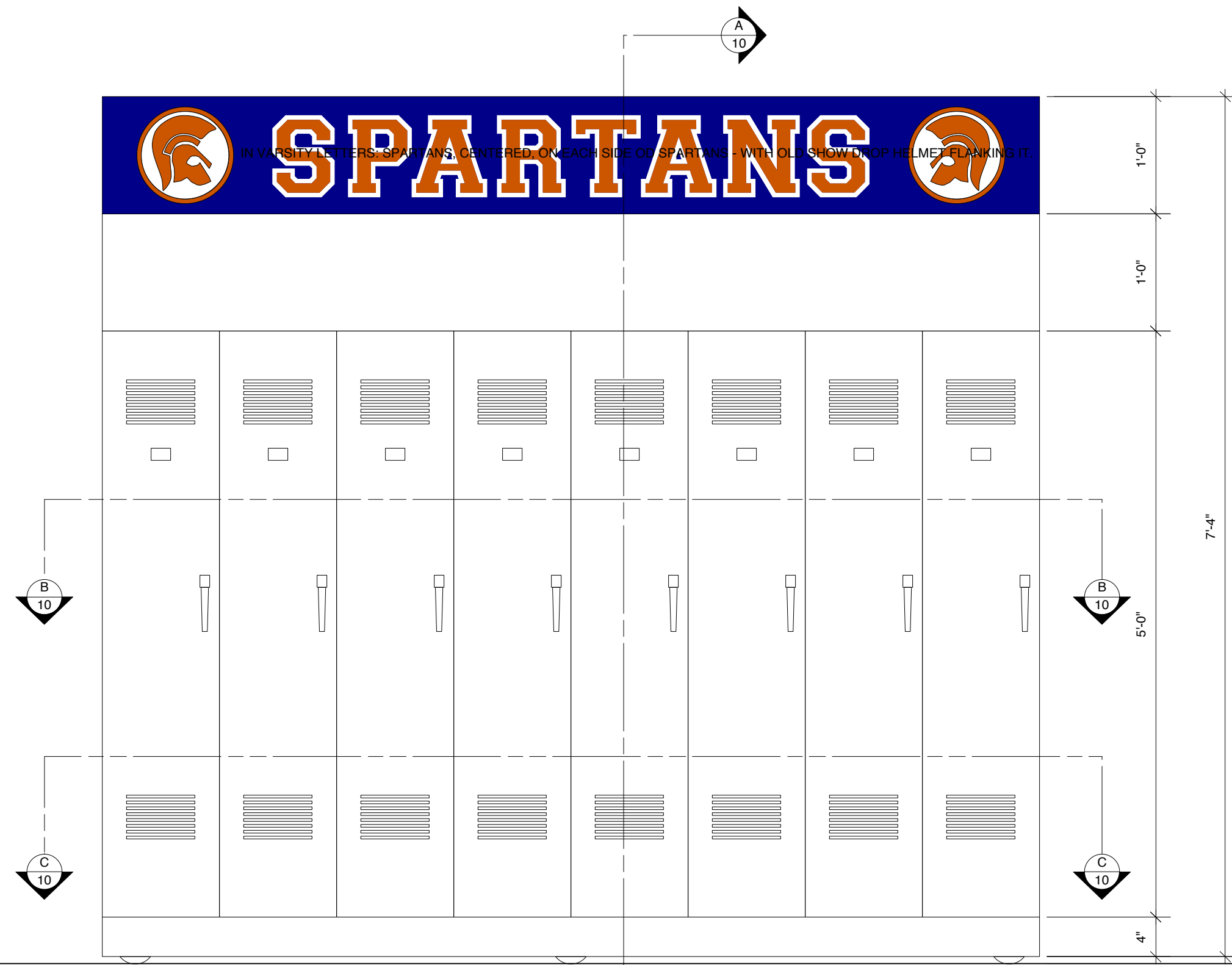
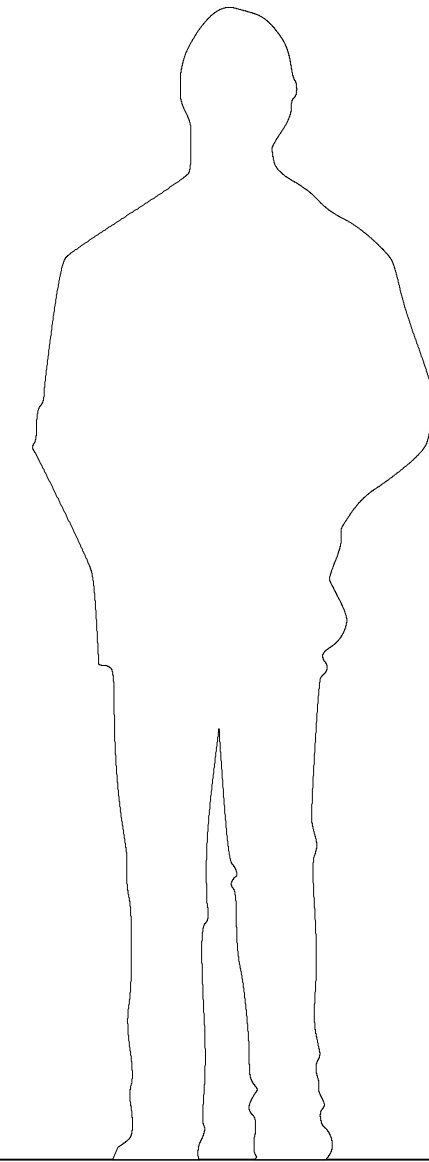

SECTION 10-B

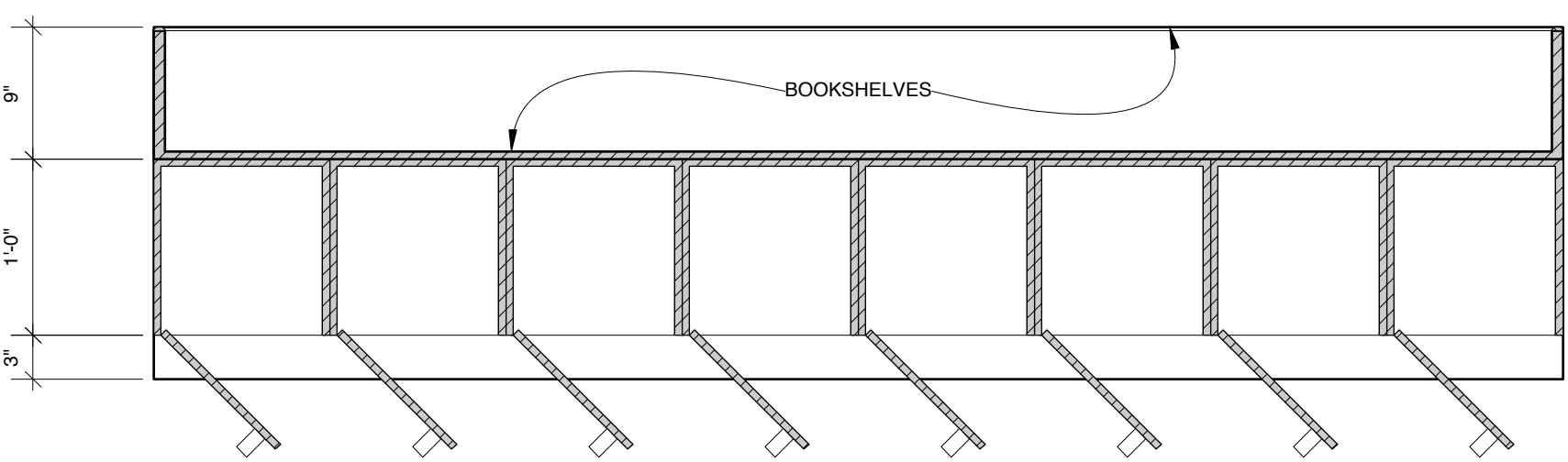

SECTION 10-C

**DETAIL 10-C
FULL SCALE**

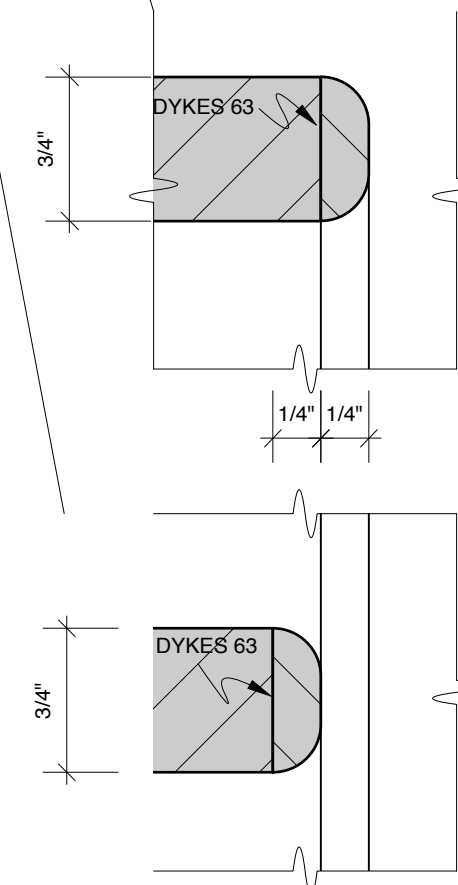

LOCKER UNIT
LYSISTRATA JONES by LEWIS FLINN & DOUGLAS CARTER BEANE
 WALTER KERR THEATER
 DIRECTED BY DAN KNECHTGES
 DESIGN BY ALLEN MOYER
 SCALE: 1" = 1'-0" DATE: OCTOBER 10, 2011

SHEET

10

SHOW CURTAIN (SCRIM)

WEBBED AND GROMMETTED ON 1'-0" CENTERS
PIPE POCKET AT BOTTOM
DISCUSS GUIDELINES ON SIDES OF SCRIM.

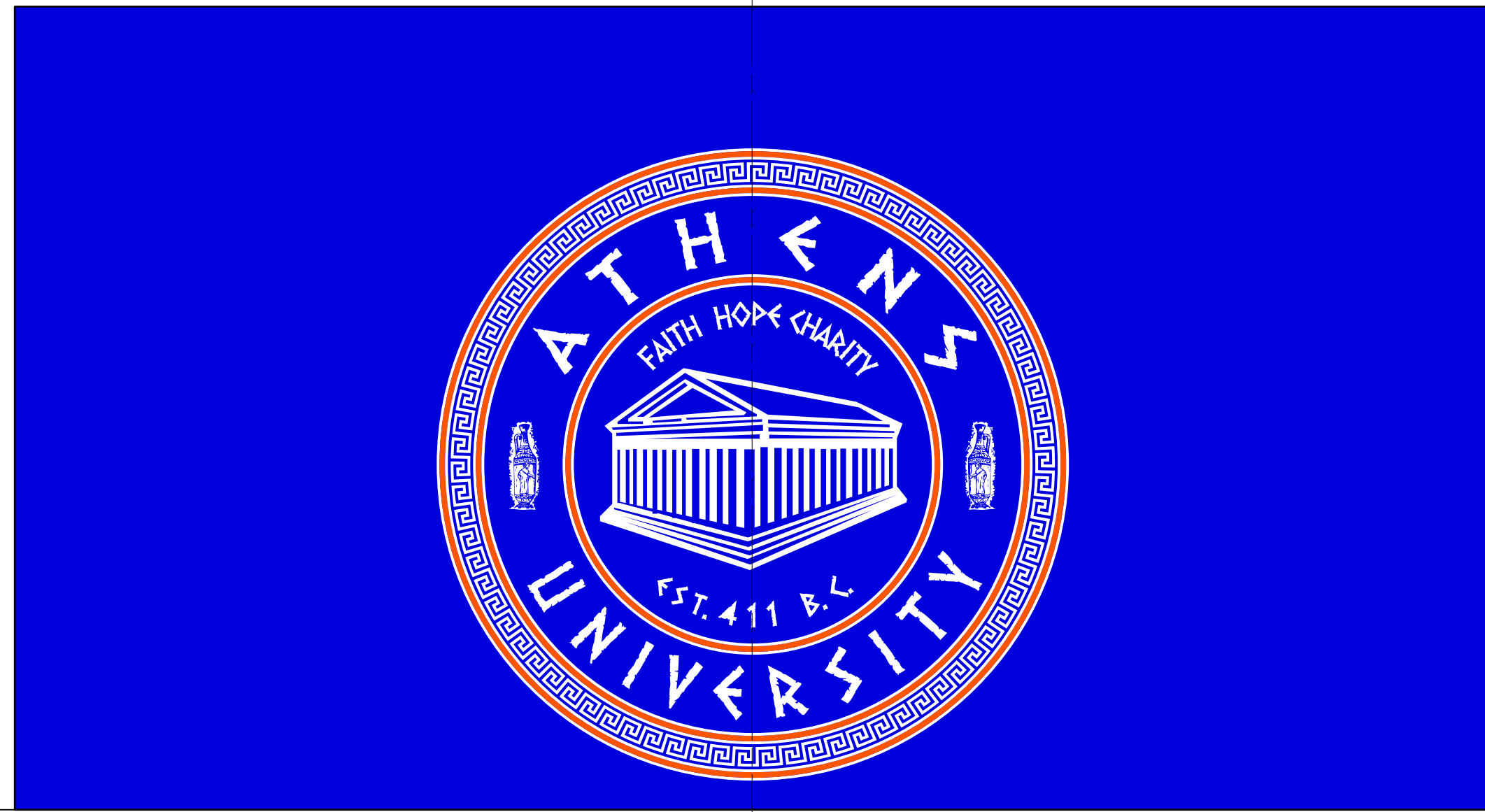

43'-11"

PLAN VIEW

CL SECTION

24'-0"

KABUKI CURTAIN & MOON LIGHT BOX

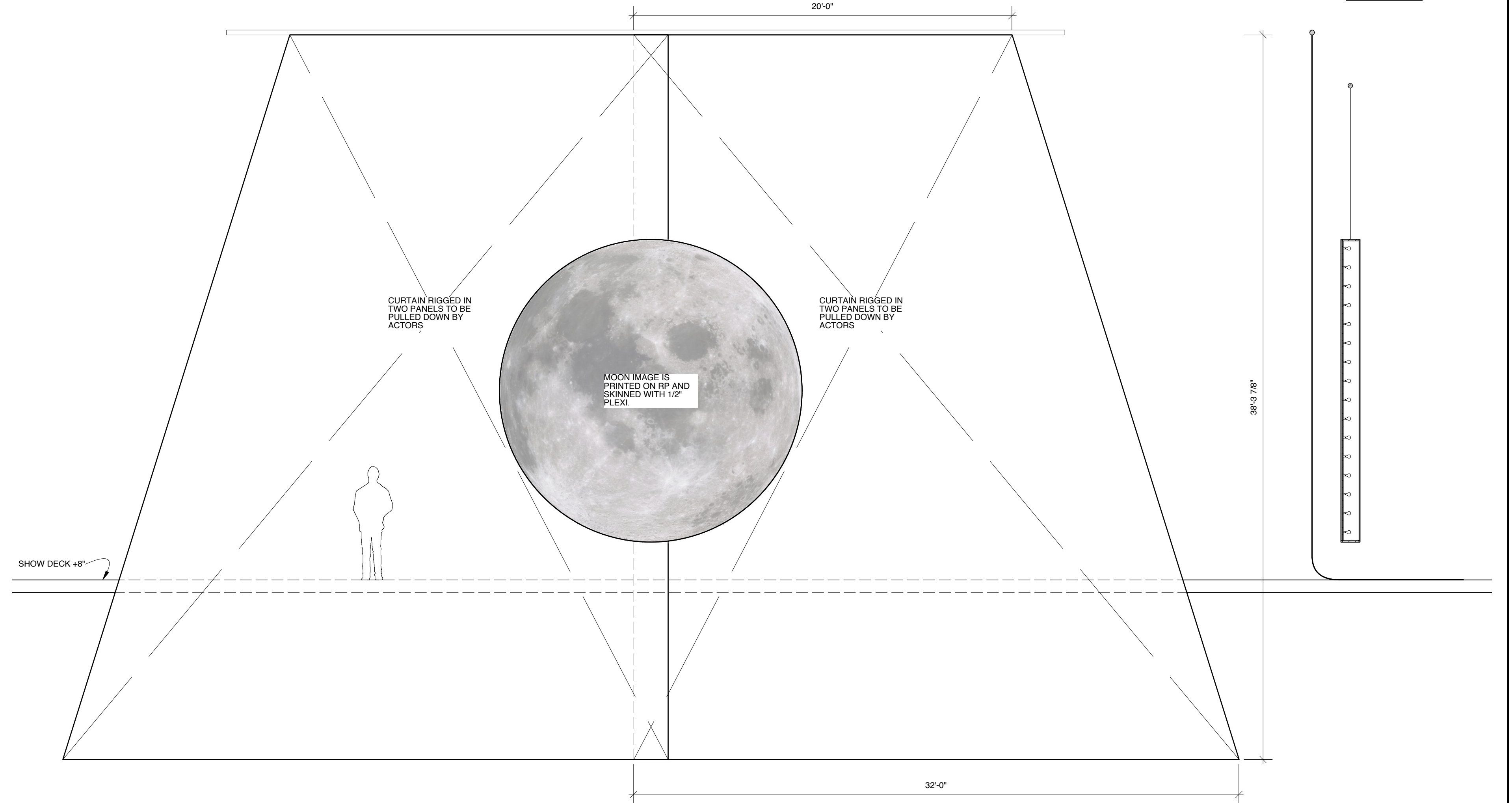

CL SECTION

38'-3 7/8"

32'-0"

BLACKOUT CURTAIN

BLACK VELOUR
WEBBED AND GROMMETTED ON 1'-0" CENTERS
PIPE POCKET AT BOTTOM

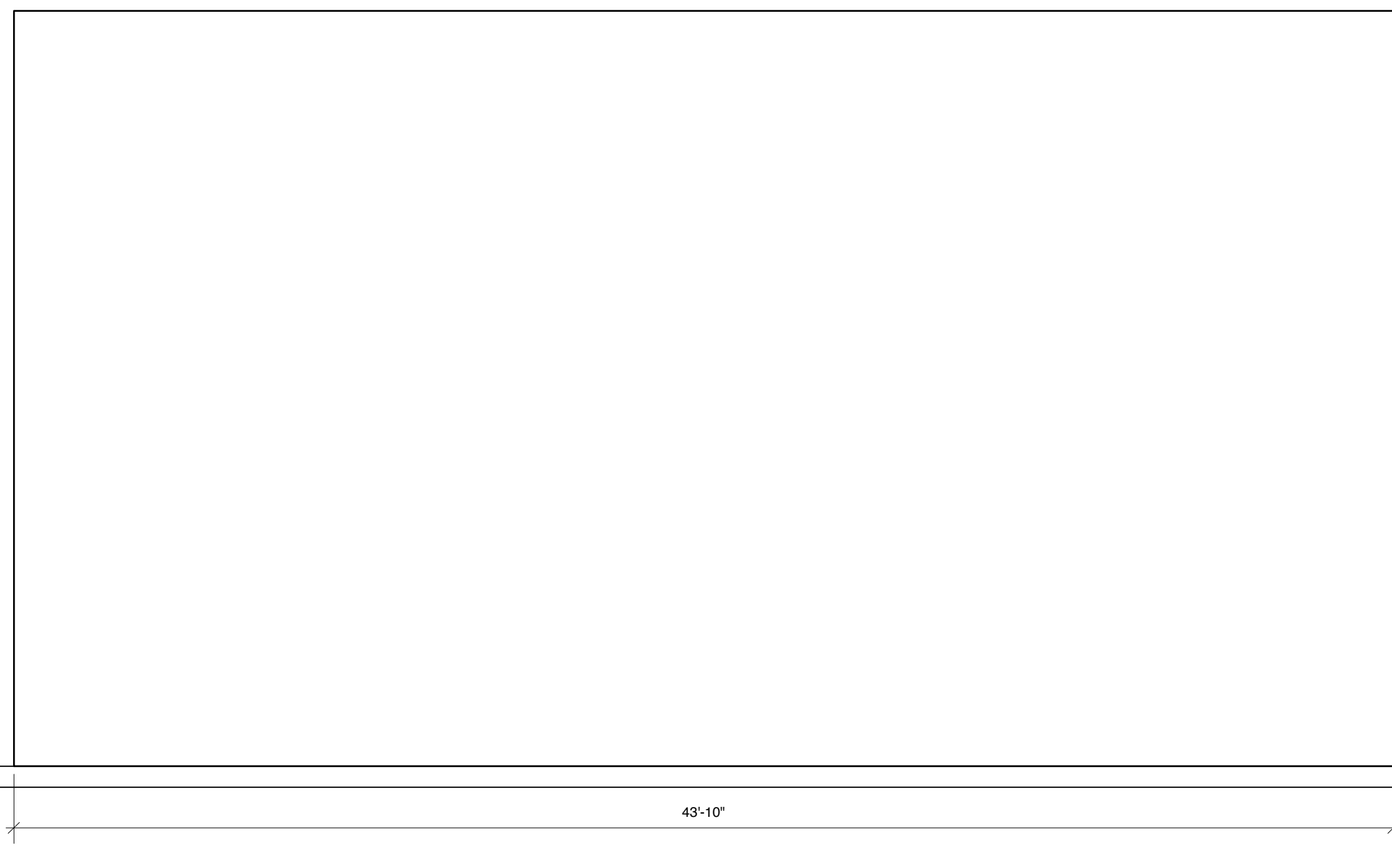

43'-10"

PLAN VIEW

SECTION 9-A

24'-0"

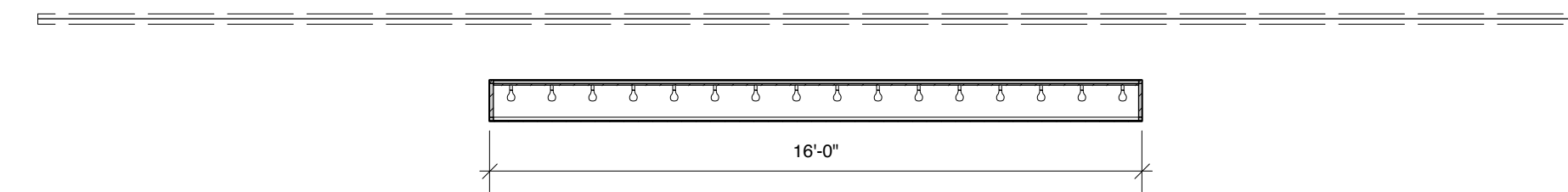

PLAN VIEW



S.D. 3347
SCENIC DESIGNER

SHOW CURTAIN (SCRIM), BLACKOUT CURTAIN, MOON LIGHTBOX & CURTAIN

LYSISTRATA JONES by LEWIS FLINN & DOUGLAS CARTER BEANE

WALTER KERR THEATER

DIRECTED BY DAN KNECHTGES

DESIGN BY ALLEN MOYER

SCALE: 1/4" = 1'-0"

DATE: OCTOBER 10, 2011

SHEET

11

DRAWN BY J. COLLINS

FLOWN EROS SIGN

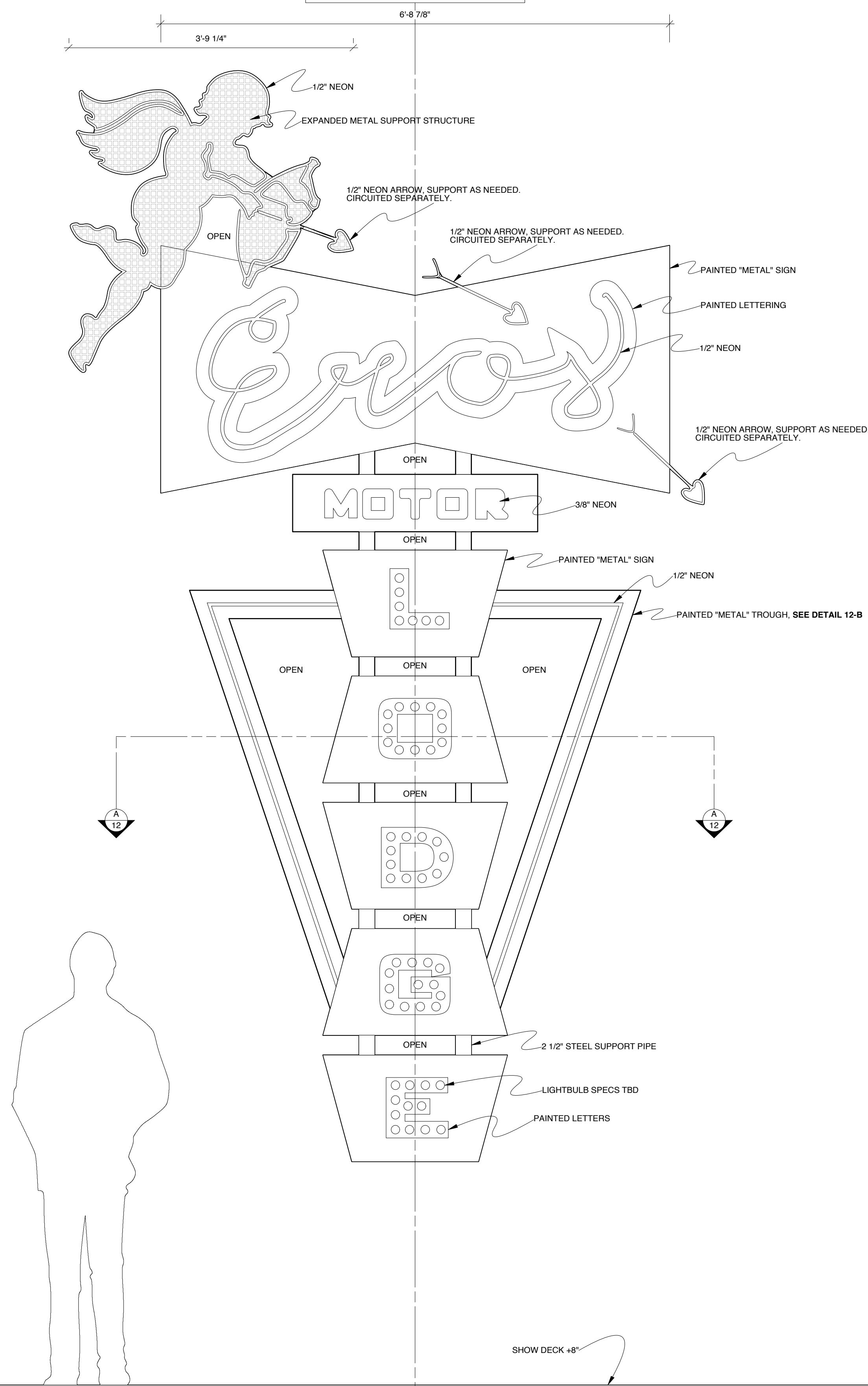

SIDE VIEW

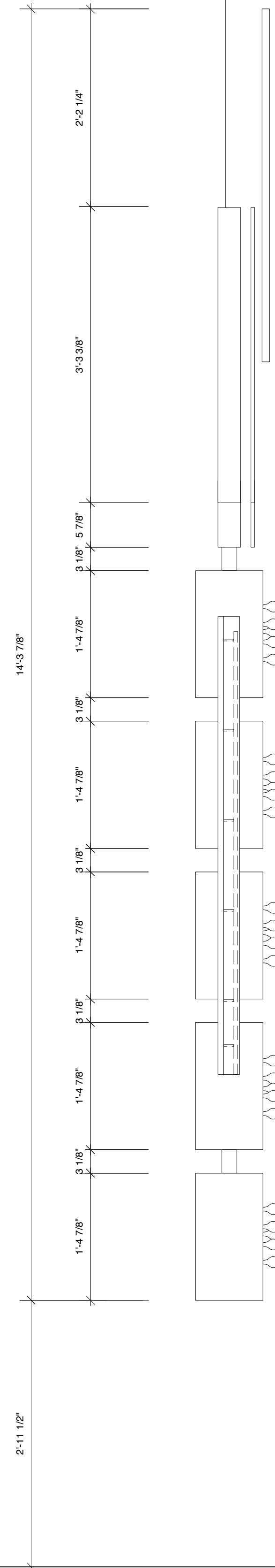

CL SECTION

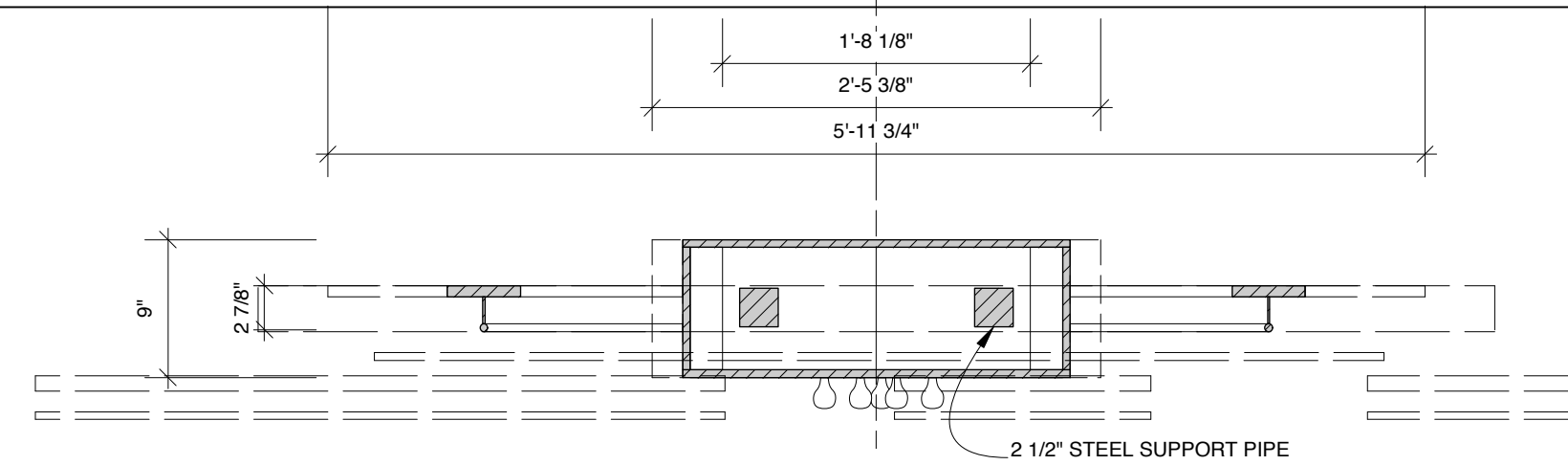
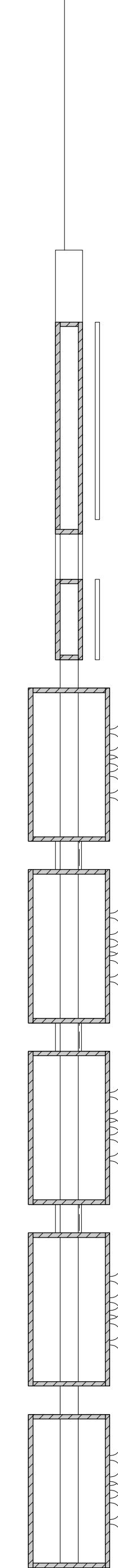

PLAN VIEW



FLOWN EROS SIGN

LYSISTRATA JONES by LEWIS FLINN & DOUGLAS CARTER BEANE

WALTER KERR THEATER

DIRECTED BY DAN KNECHTGES

DESIGN BY ALLEN MOYER

SCALE: 1" = 1'-0"

DATE: OCTOBER 10, 2011

SHEET

12

FLOWN BEADED FINALE CURTAINS

FLOWN CURTAIN:
219 26'-6" STRANDS OF ROSEBRAND "DISCO BALL B." GOLD.
STRANDS PLACED ON 2" CENTERS.

CL SECTION

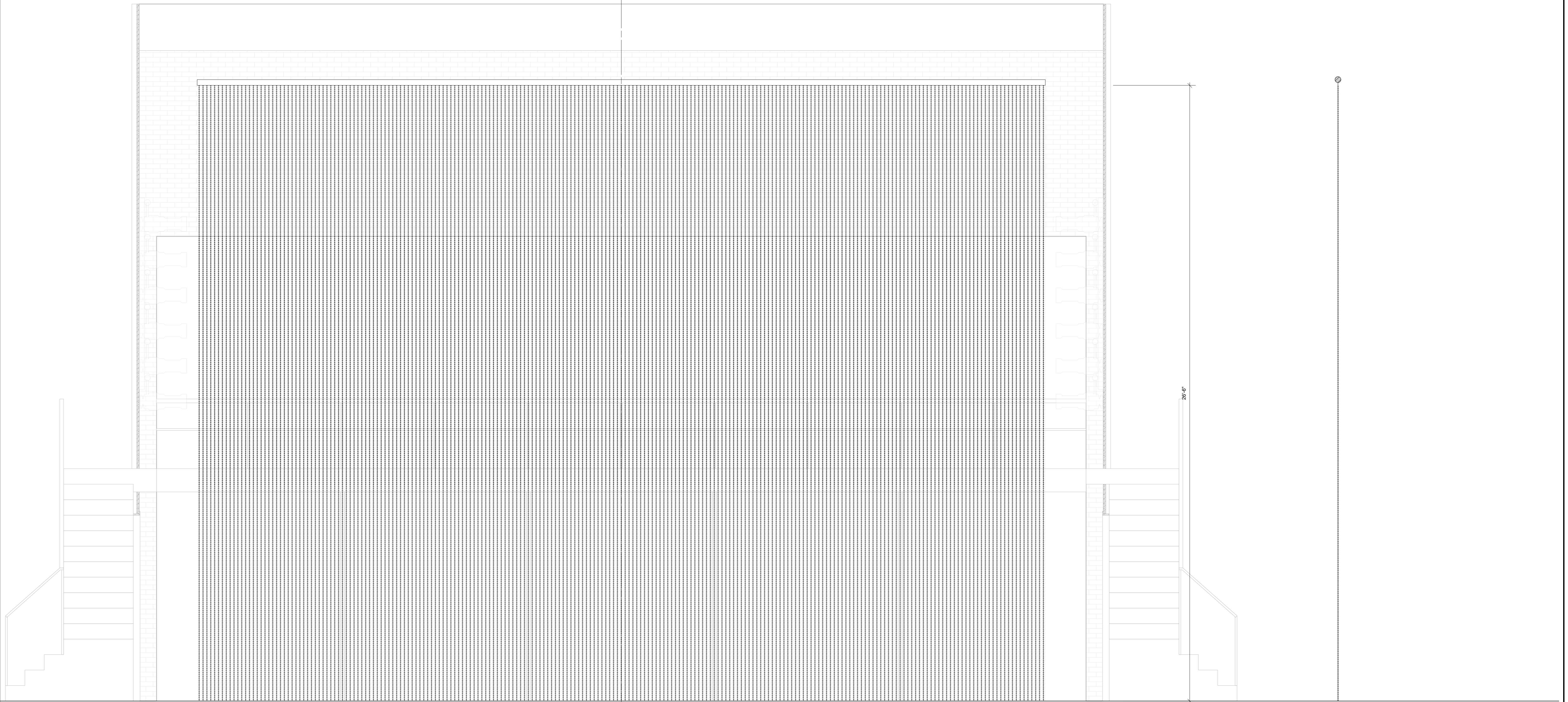

36'-6"

26'-6"

PLAN VIEW



S.D. 3347
SCENIC DESIGNER

FLOWN BEADED FINALE CURTAIN

LYSISTRATA JONES by LEWIS FLINN & DOUGLAS CARTER BEANE

WALTER KERR THEATER

DIRECTED BY DAN KNECHTGES

DESIGN BY ALLEN MOYER

SCALE: 1/2" = 1'-0"

DATE: OCTOBER 10, 2011

DRAWN BY J. COLLINS

SHEET

13

TRACKED GYM CURTAIN

DRAWN FLAT - BUILD WITH 100% FULLNESS. DISCUSS.
 VELOUR - 21 OZ MARVEL
 FINAL COLORS: CORNFLOWER, SIENNA, AND DOVE.

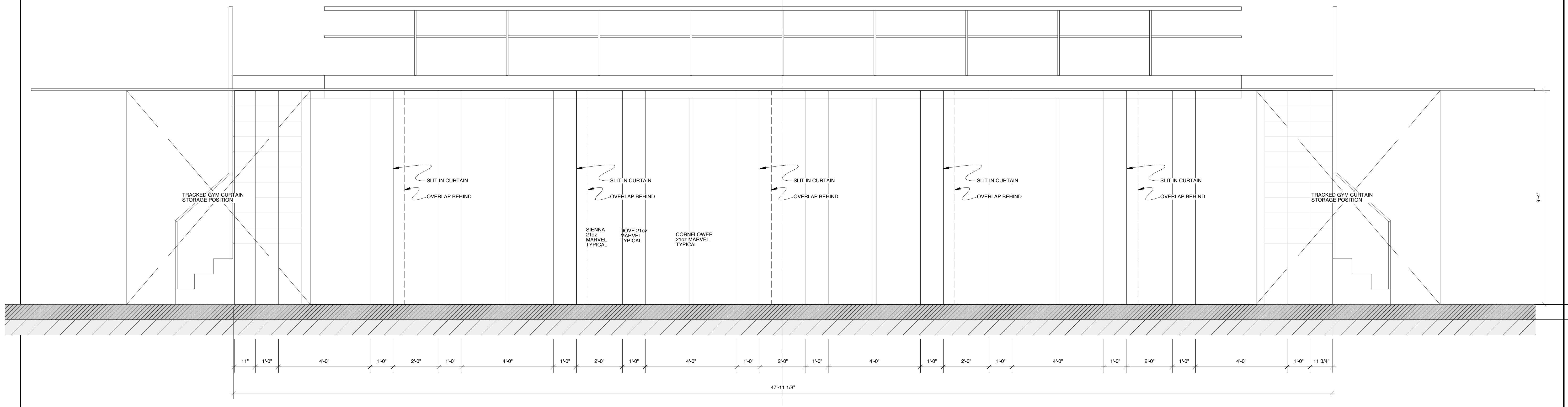

PLAN VIEW

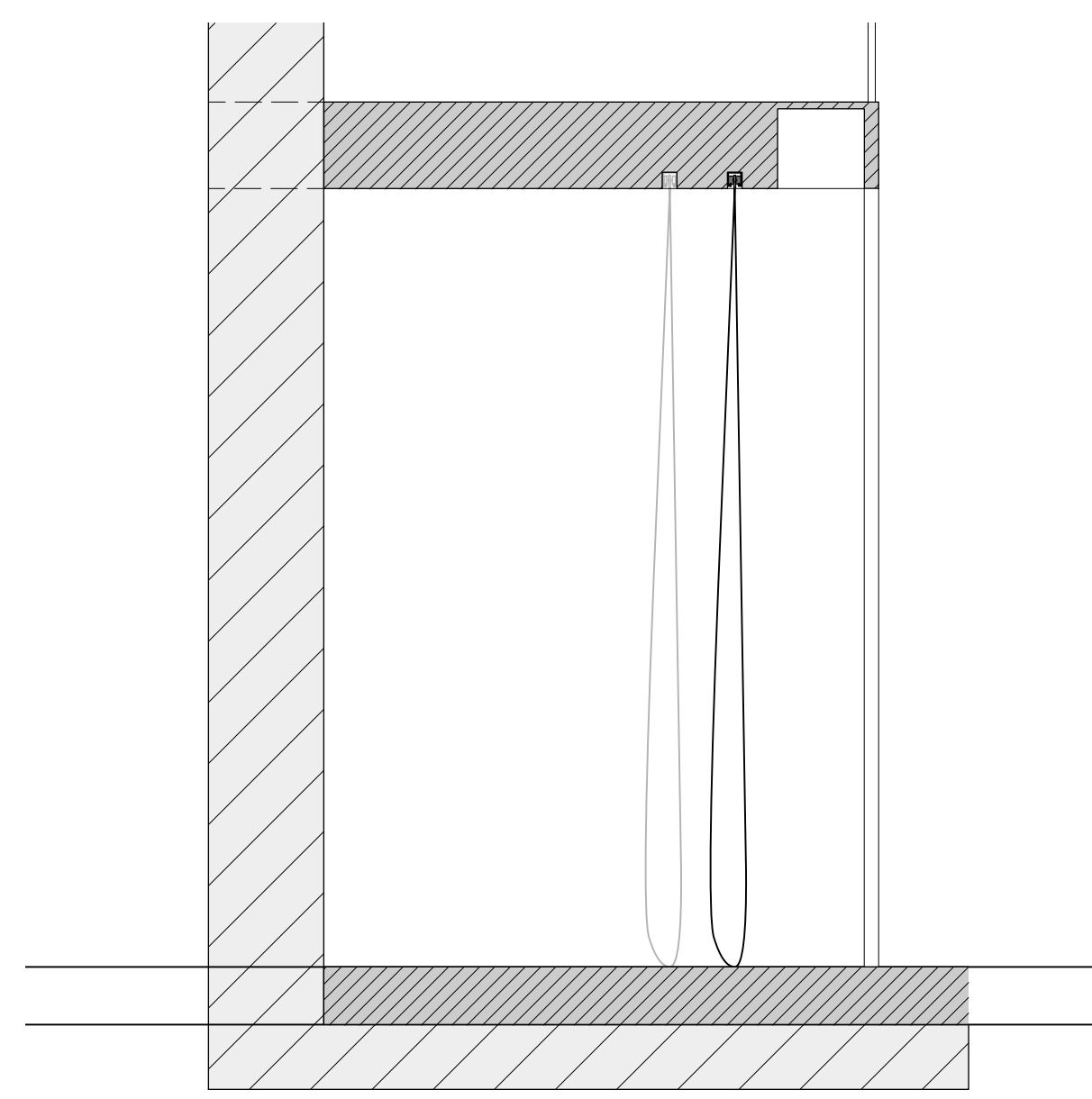

CL SECTION

<p>S.D. 3347 SCENIC DESIGNER</p>	<p>TRACKED Gym Curtain</p>	<p>SHEET</p> <p>14</p>
	<p>LYSISTRATA JONES by LEWIS FLINN & DOUGLAS CARTER BEANE</p>	
	<p>WALTER KERR THEATER DIRECTED BY DAN KNECHTGES DESIGN BY ALLEN MOYER</p>	
	<p>SCALE: 1/2" = 1'-0" DATE: OCTOBER 10, 2011</p>	

TRACKED EROS CURTAIN

CHIFFON CURTAIN WITH FULLNESS TBD.
PARTS IN CENTER AND STORES OFFSTAGE LEFT AND RIGHT.

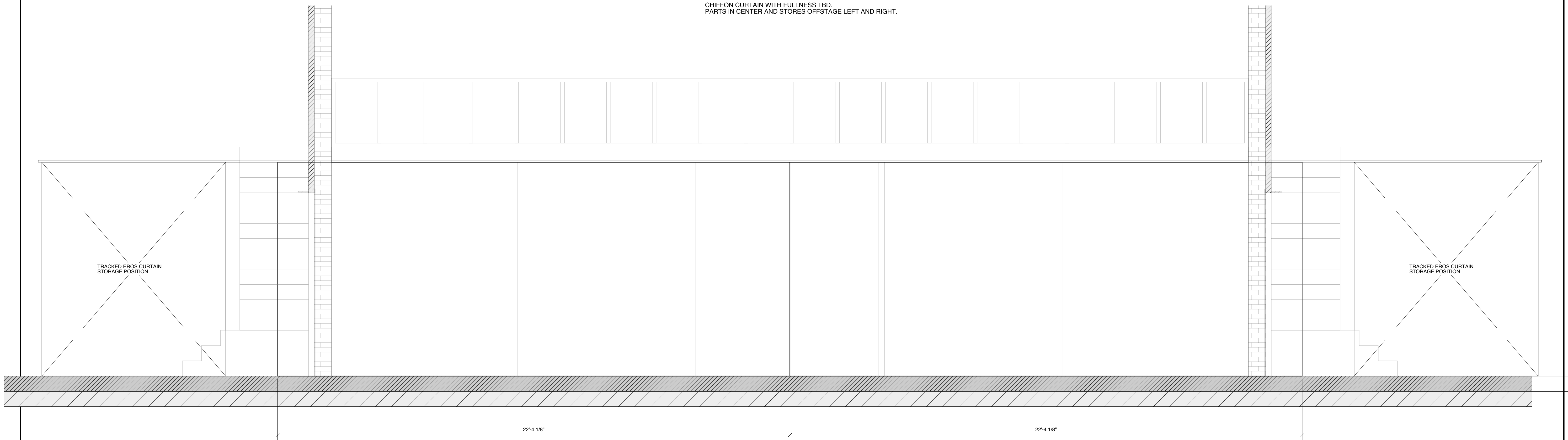

PLAN VIEW

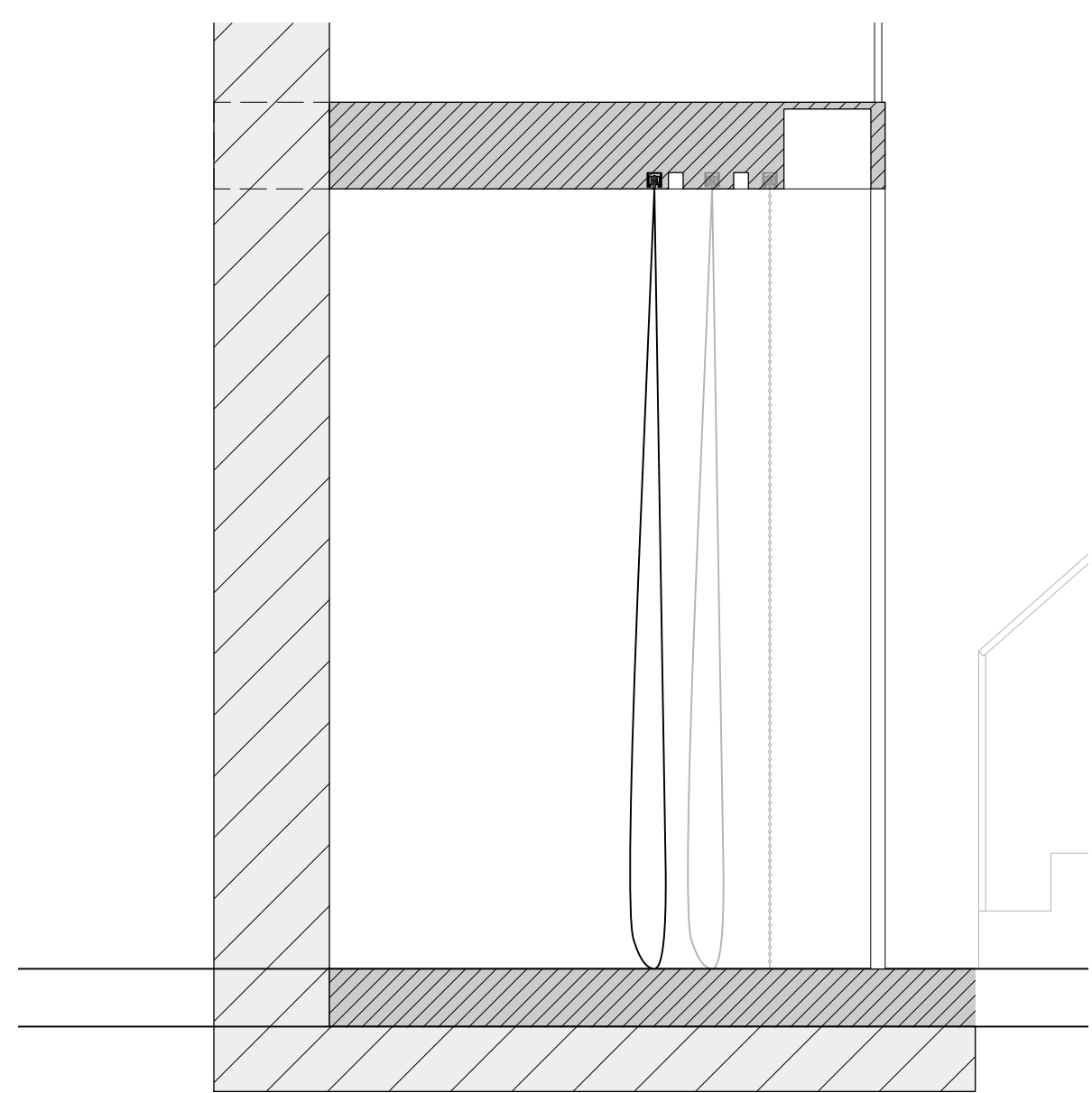
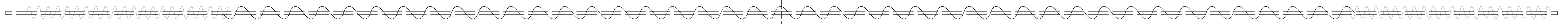

CL SECTION

	TRACKED EROS CURTAIN		SHEET 15
	LYSISTRATA JONES by LEWIS FLINN & DOUGLAS CARTER BEANE		
	WALTER KERR THEATER		
	DIRECTED BY DAN KNECHTGES		
	DESIGN BY ALLEN MOYER		
SIGNATURE _____	SCALE: 1/2" = 1'-0"	DATE: OCTOBER 10, 2011	

FLOWN BACCHANAL CURTAIN & LIGHT BULB UNIT

CURTAIN IS DRAPED ROSEBRAND METALLIC KNIT BOUCLÉ.
 FRAMED PLEXI IS SURROUNDED BY MEDIUM BASE CHASING BELT LIGHT, SEE LD FOR SPECS.
 LETTERS ARE APPLIQUE GOLD VINYL ON TOP OF PLEXI.

CL SECTION

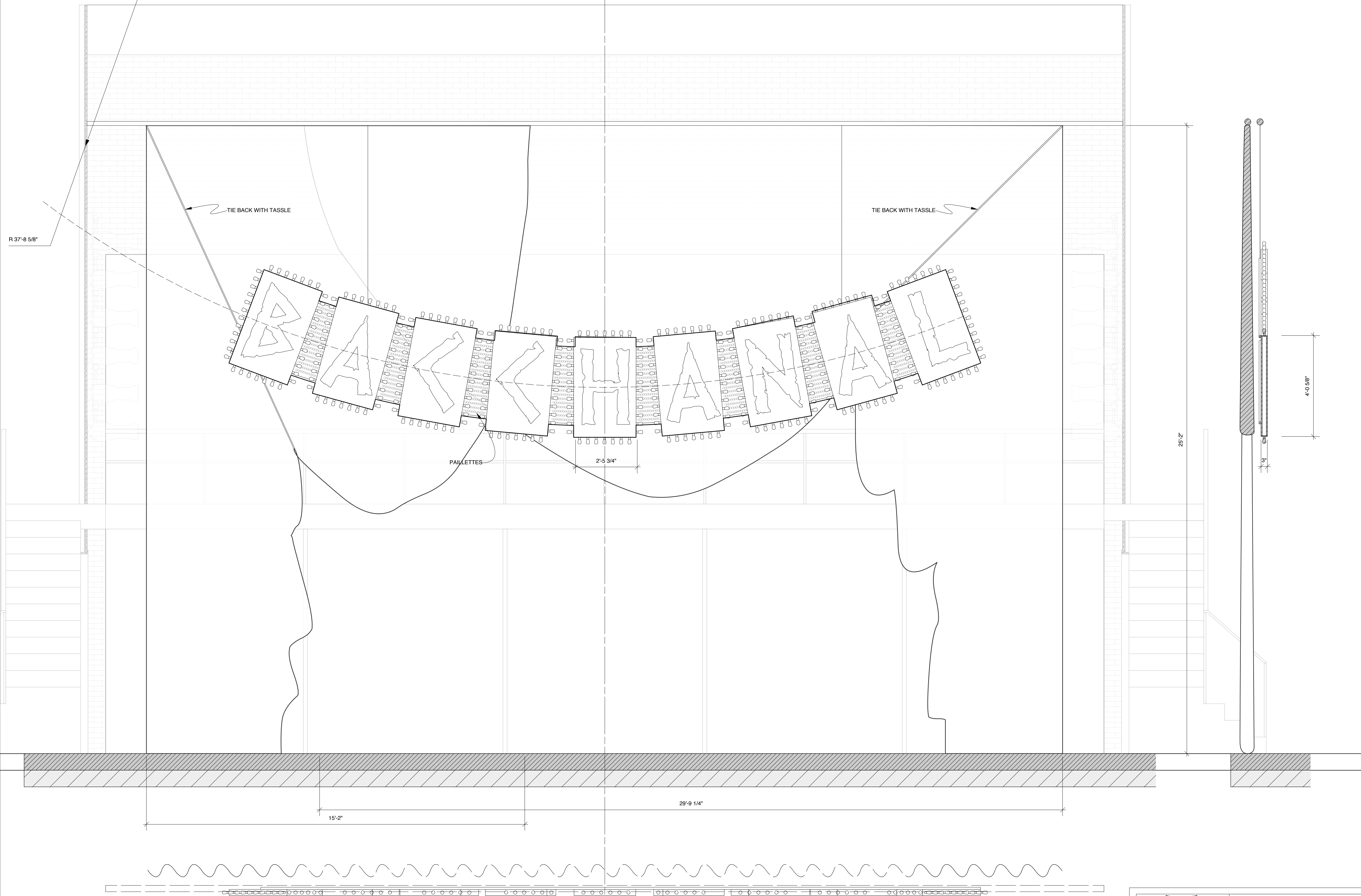

PLAN VIEW

<p>S.D. 3347 SCENIC DESIGNER</p>	FLOWN BACCHANAL LIGHTBOX & CURTAIN		SHEET 16
	LYSISTRATA JONES by LEWIS FLINN & DOUGLAS CARTER BEANE		
	WALTER KERR THEATER		
	DIRECTED BY DAN KNECHTGES		
	DESIGN BY ALLEN MOYER		
SCALE: 1/2" = 1'-0"	DATE: OCTOBER 10, 2011		

LIGHT WALL & SCRIM

10 1/2" CLIP LIGHT REFLECTOR (450 TOTAL)
MIRROR-TIPPED EDISON BASE BULBS (450 TOTAL)

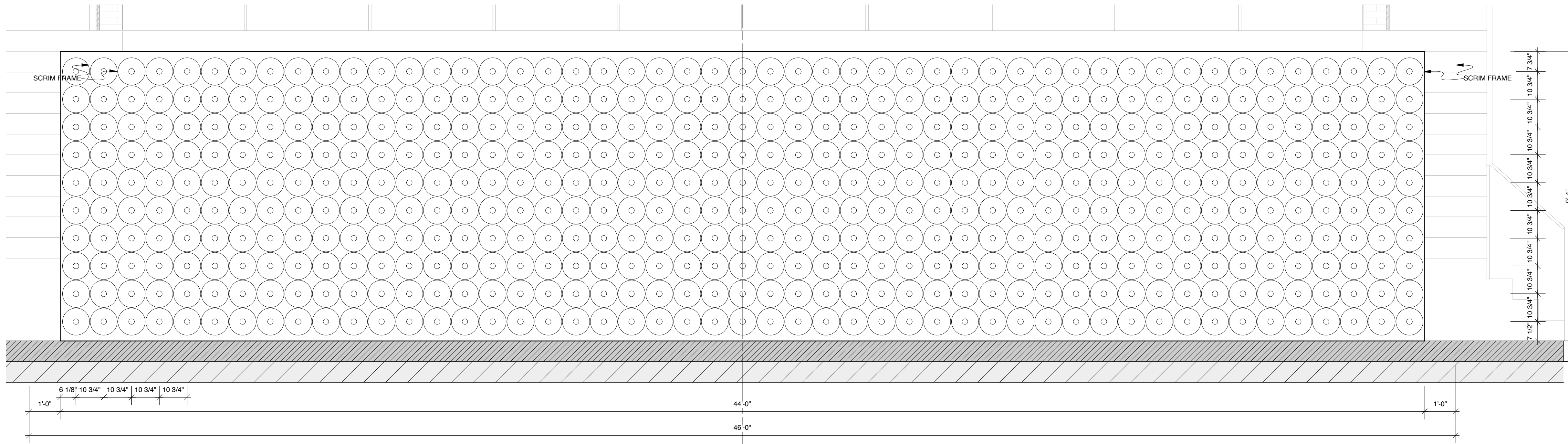

CL SECTION

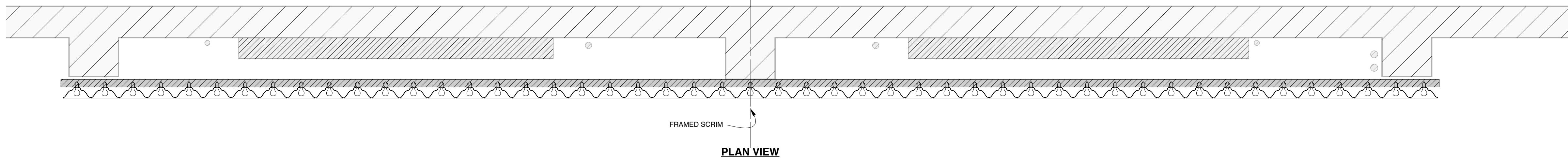
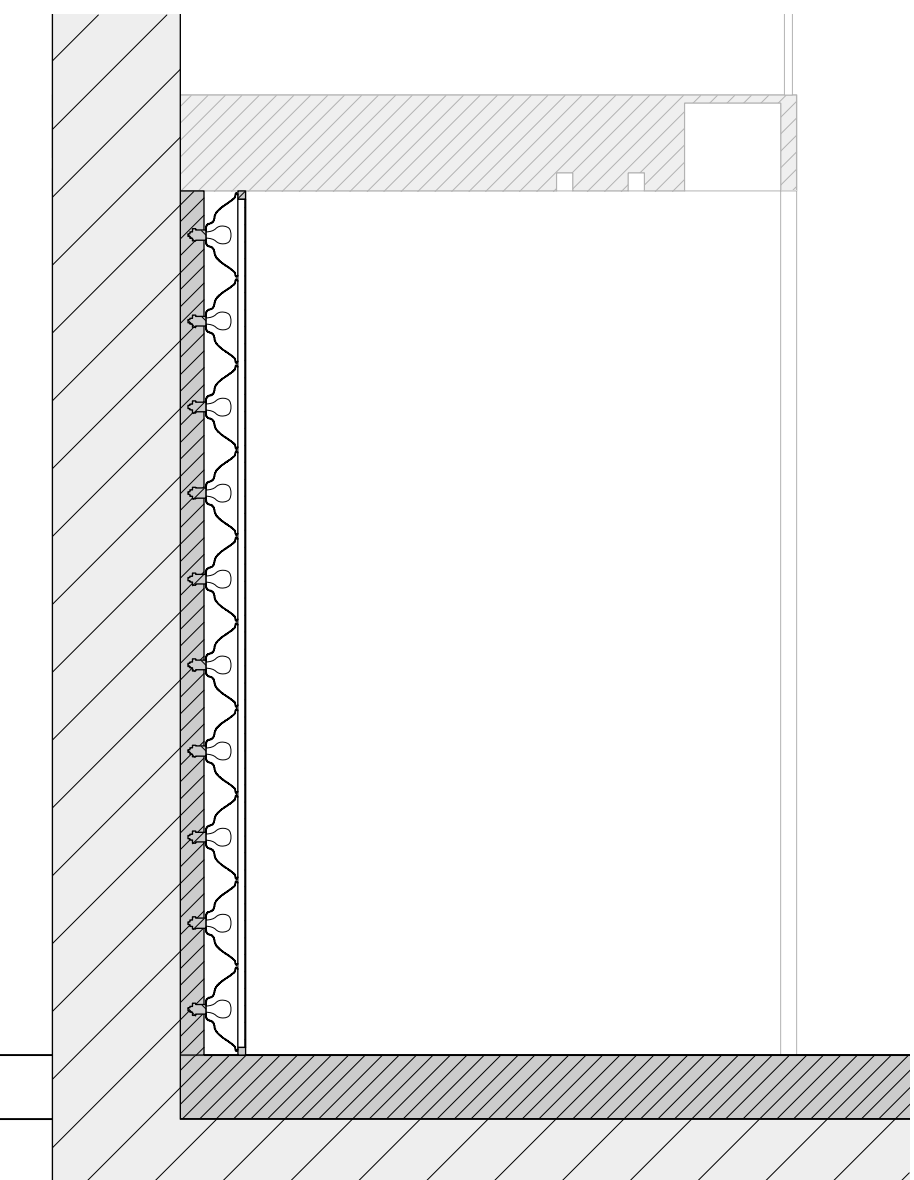

BORDER

BLACK VELOUR

CL SECTION

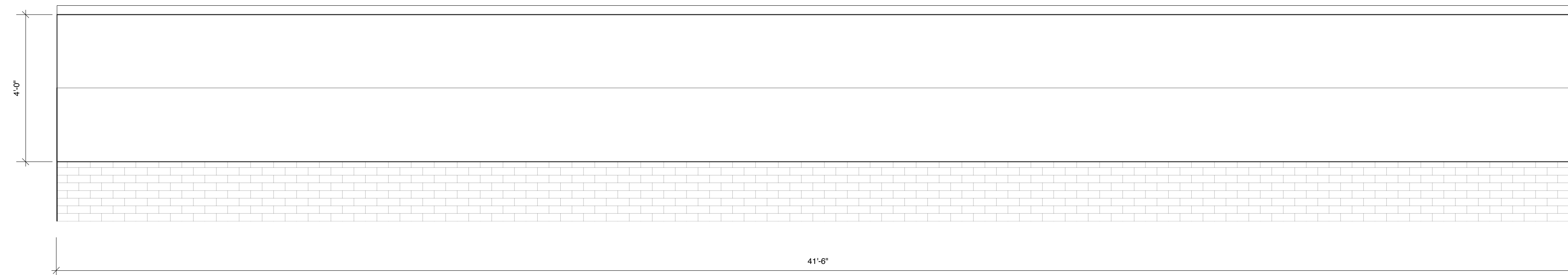

<p>S.D. 3347 SCENIC DESIGNER</p>	LIGHT WALL & SCRIM, BORDER		SHEET <h1>17</h1>
	LYSISTRATA JONES by LEWIS FLINN & DOUGLAS CARTER BEANE		
	WALTER KERR THEATER		
	DIRECTED BY DAN KNECHTGES		
	DESIGN BY ALLEN MOYER		
SCALE: 1/2" = 1'-0"	DATE: OCTOBER 10, 2011	DRAWN BY J. COLLINS	

CENTERLINE SECTION

AUTOMATED CHARIOT TRACKS DOWN CS TRACK AND ROTATES FREELY.
 INTERIOR OF CHARIOT IS UPHOLSTERED AND TUFTED.
 SEAT IS CUSHIONED.
 HINGED DOORS ALLOW ACTOR TO EXIT CHARIOT, USING PEACOCK AS A STEP DOWN TO SHOW DECK.

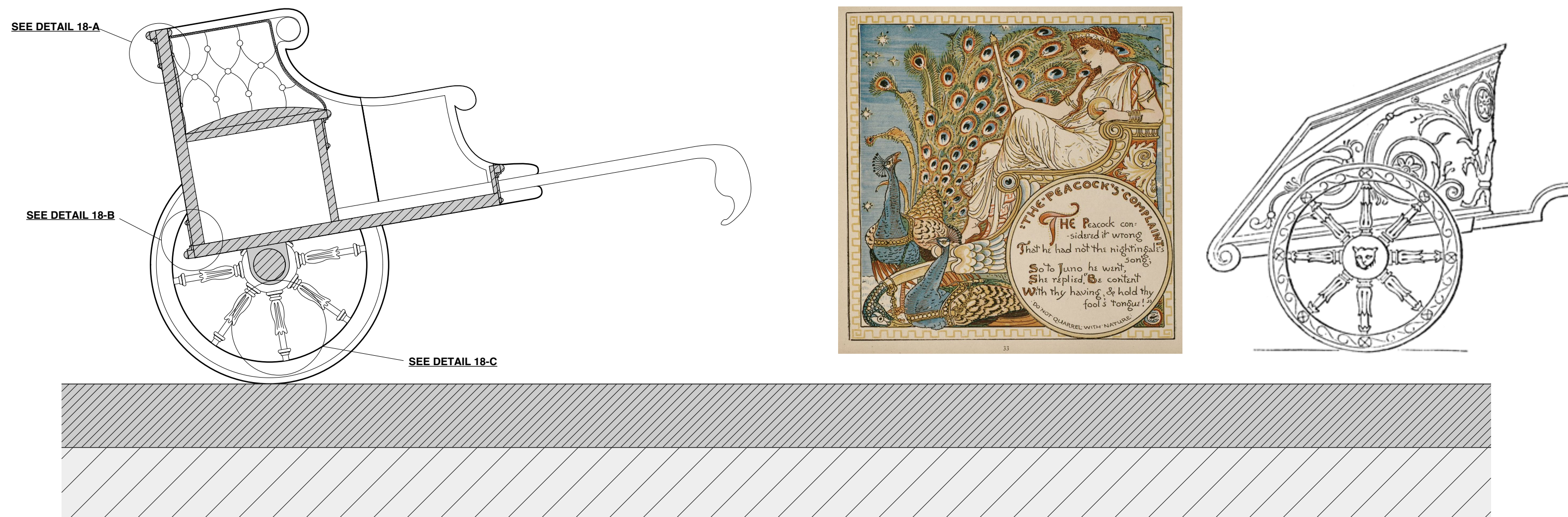

TRACKED CHARIOT

AUTOMATED CHARIOT TRACKS DOWN CS TRACK AND ROTATES FREELY.
 SCULPTED PEACOCK AND CHARIOT ARE GOLDFLEAFED.
 HINGED DOORS ALLOW ACTOR TO EXIT CHARIOT, USING PEACOCK AS A STEP DOWN TO SHOW DECK.
 REAR OF CHARIOT WILL HAVE A LASER CUT APPLIQUE TBD.
 PEACOCK IS "HARNESSED" TO CHARIOT, UPDATED DRAWING TBD.

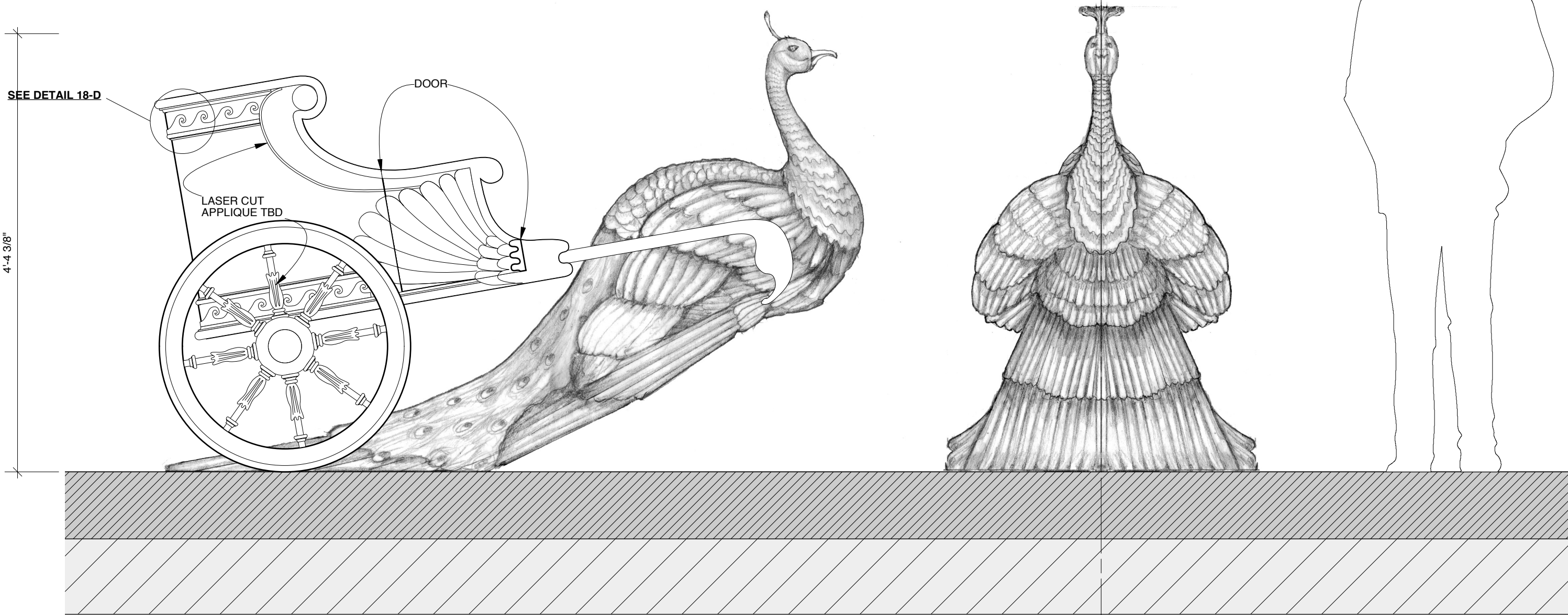

SIDE VIEW

PLAN VIEW

AUTOMATED CHARIOT TRACKS DOWN CS TRACK AND ROTATES FREELY.
 HINGED DOORS ALLOW ACTOR TO EXIT CHARIOT, USING PEACOCK AS A STEP DOWN TO SHOW DECK.

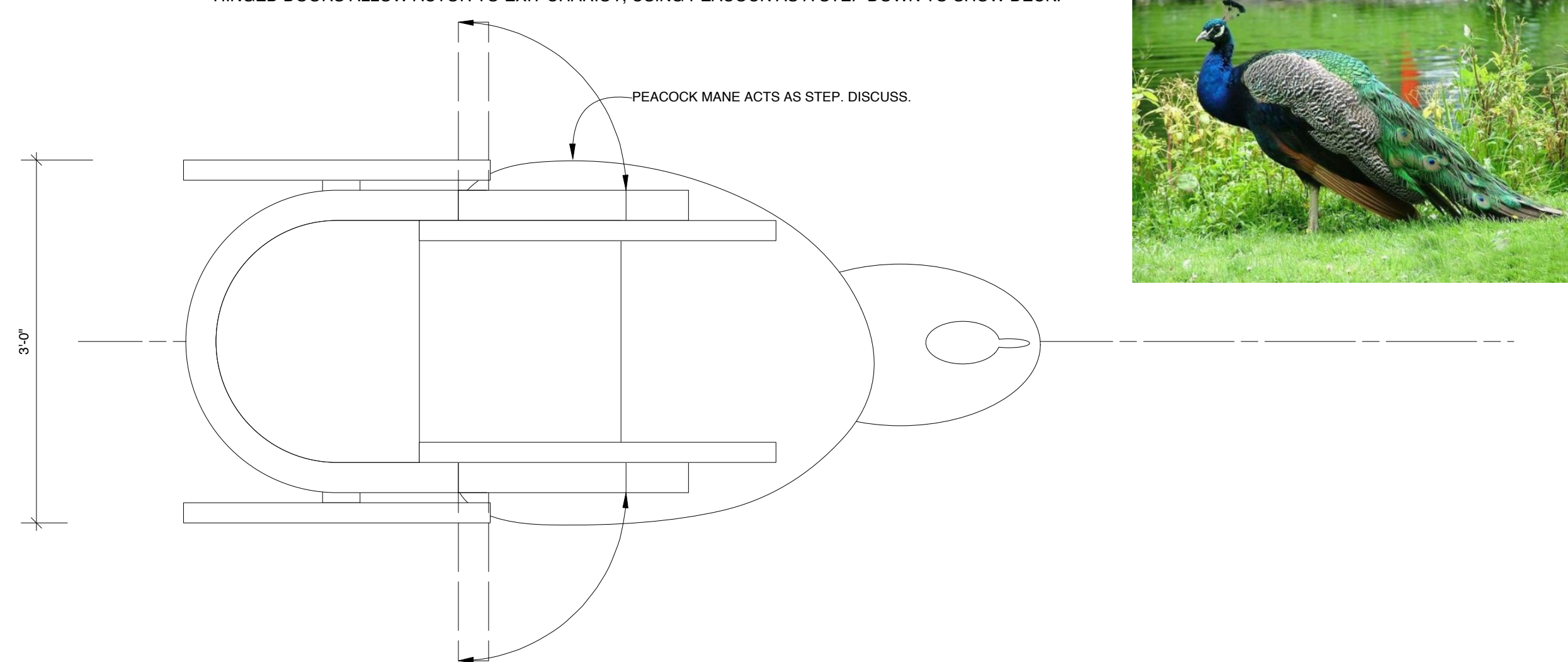

DETAIL 18-A

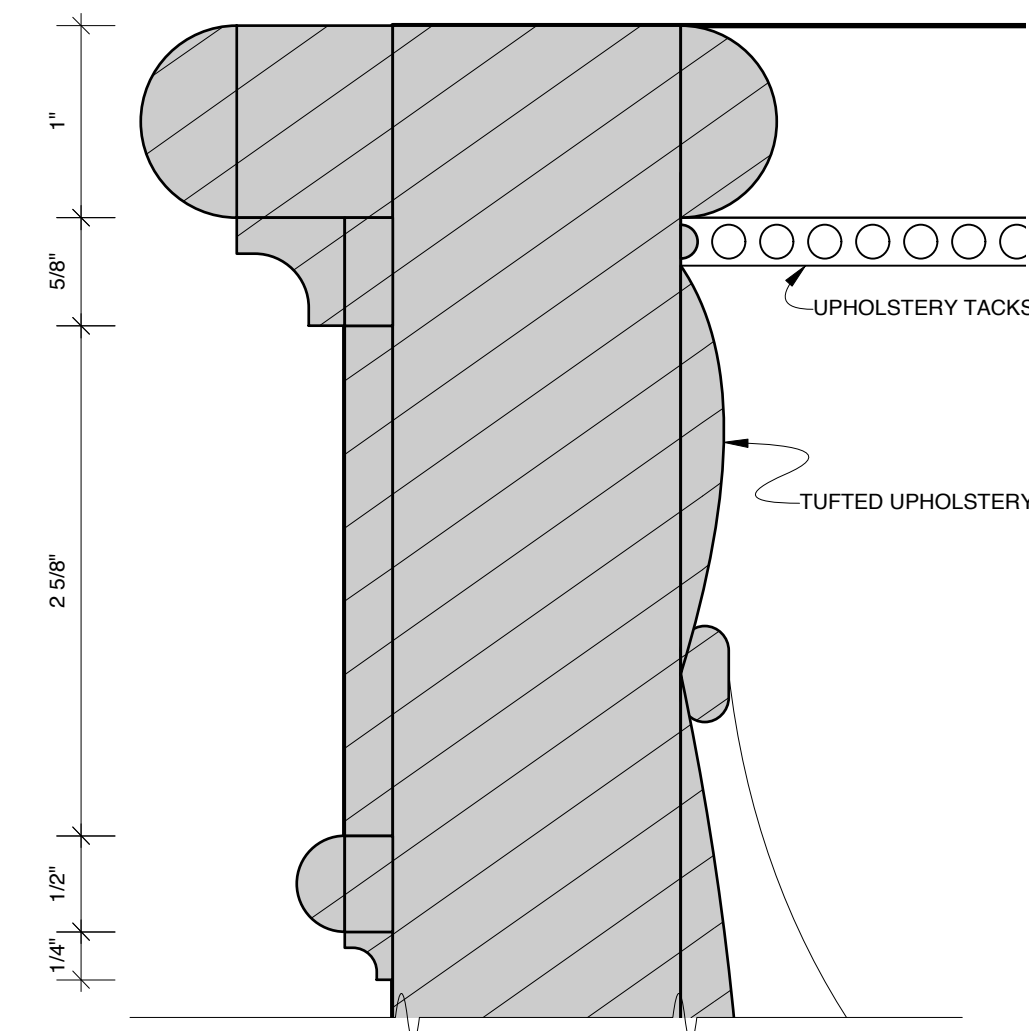

DETAIL 18-B

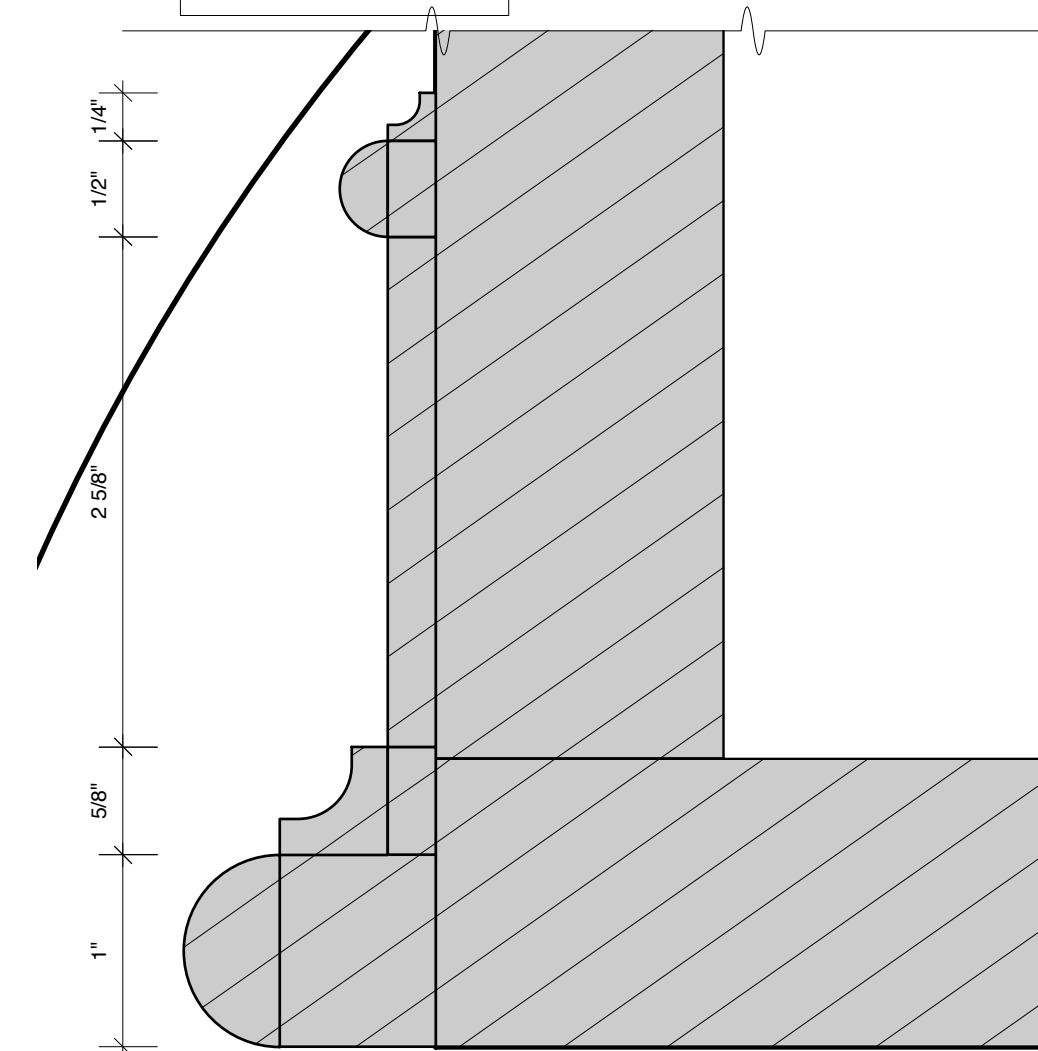

DETAIL 18-D

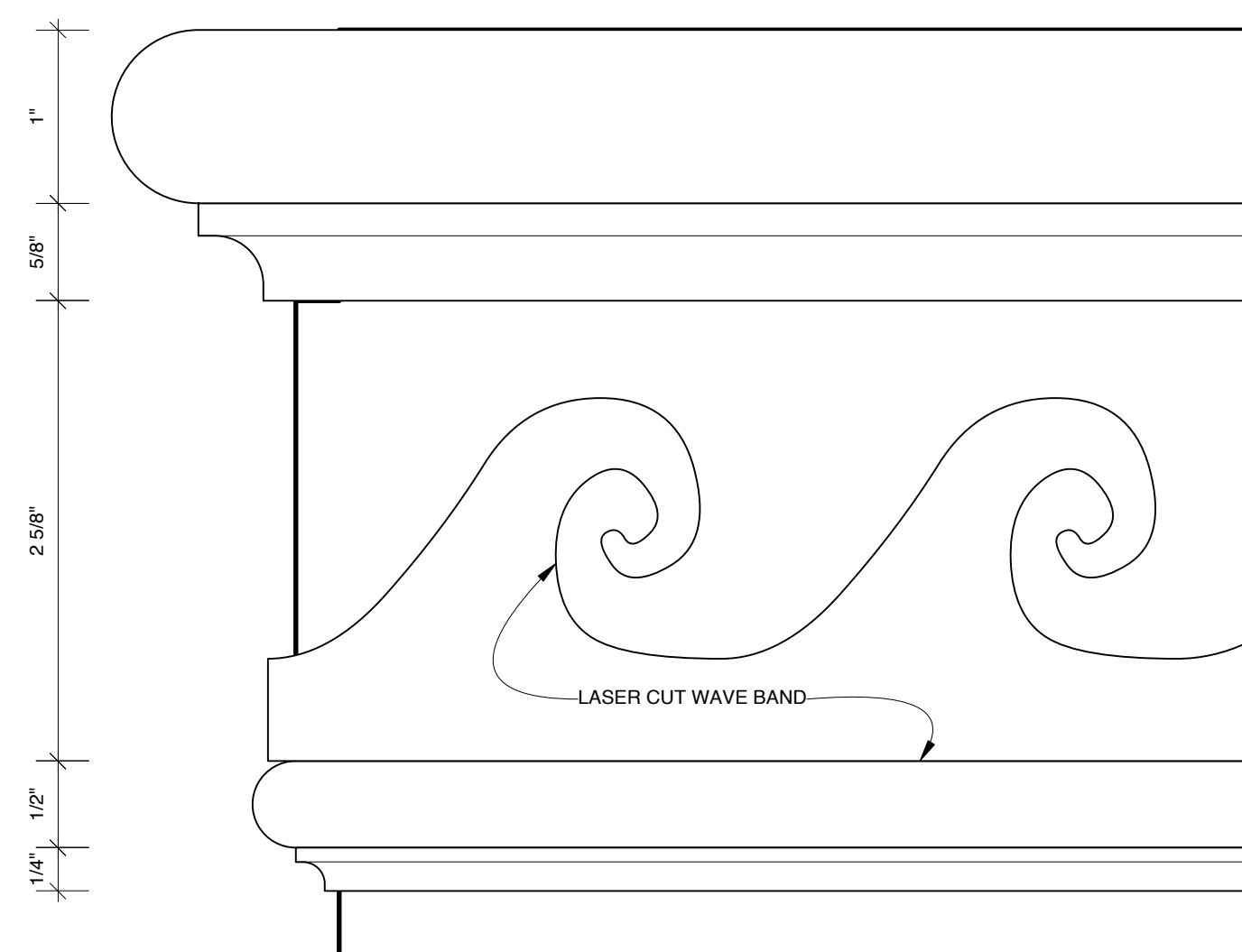

DETAIL 18-C

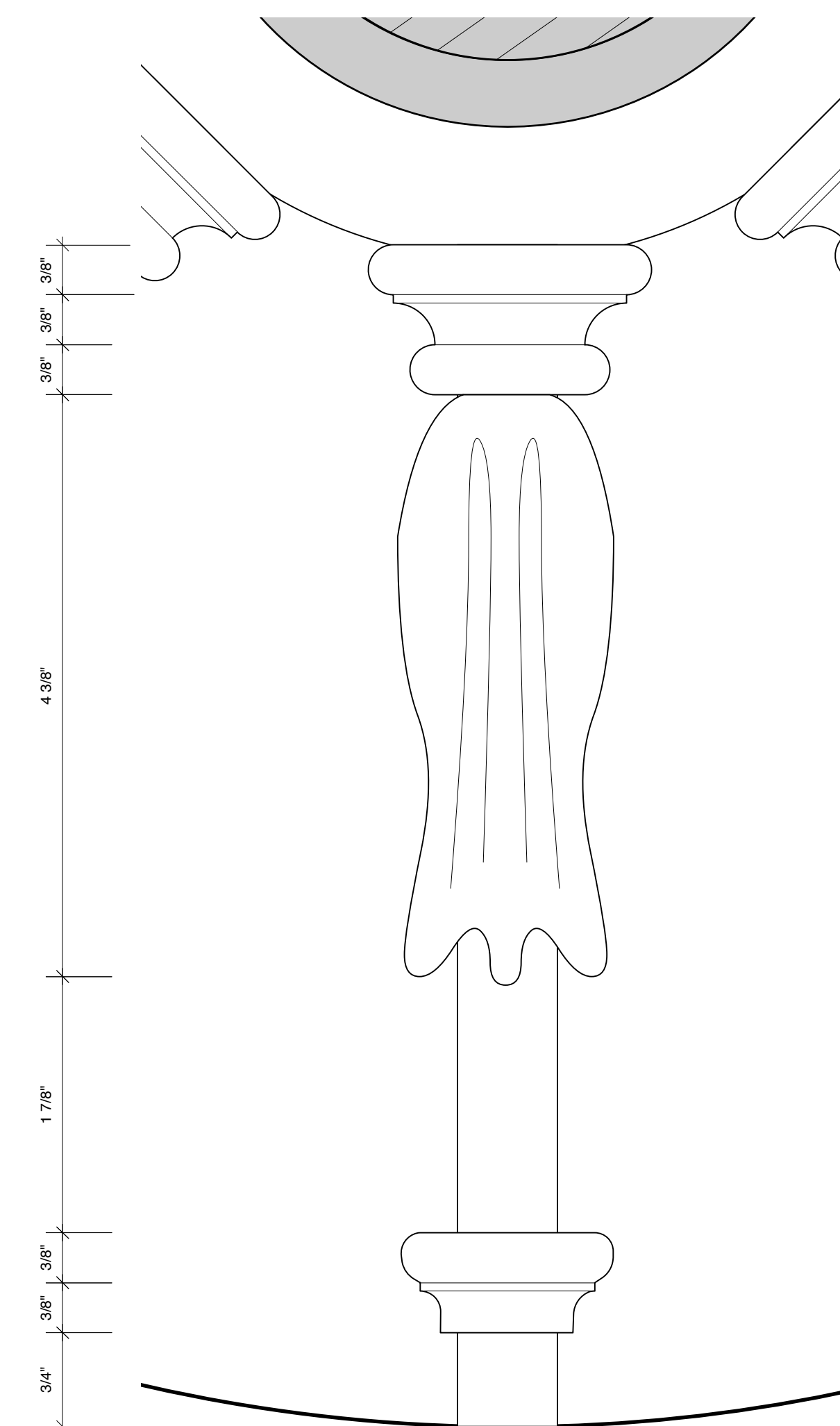

<p>S.D. 3347 SCENIC DESIGNER</p>	TRACKED CHARIOT		SHEET <h1>18</h1>
	LYSISTRATA JONES by LEWIS FLINN & DOUGLAS CARTER BEANE		
	WALTER KERR THEATER		
	DIRECTED BY DAN KNECHTGES		
	DESIGN BY ALLEN MOYER		
SCALE: 1" = 1'-0"	DATE: OCTOBER 10, 2011	DRAWN BY J. COLLINS	

RESEARCH

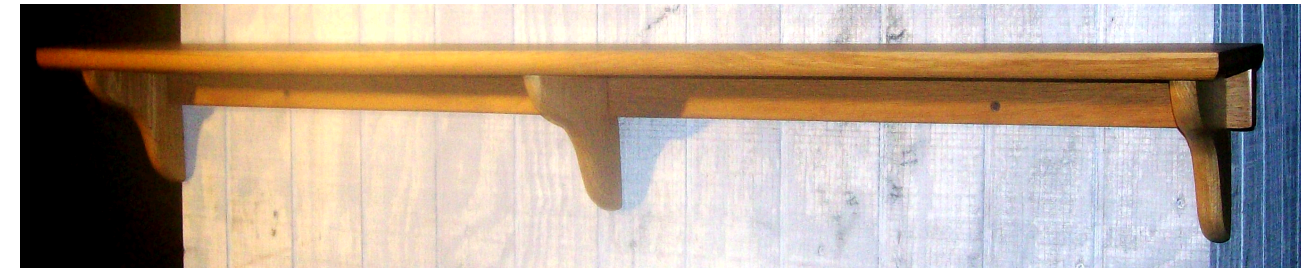

FLOWN SHELF UNIT

RIGGED TO FLY. DISCUSS RIGGING HARDWARE SPECS AND LOCATION.
DRESSING TBD.

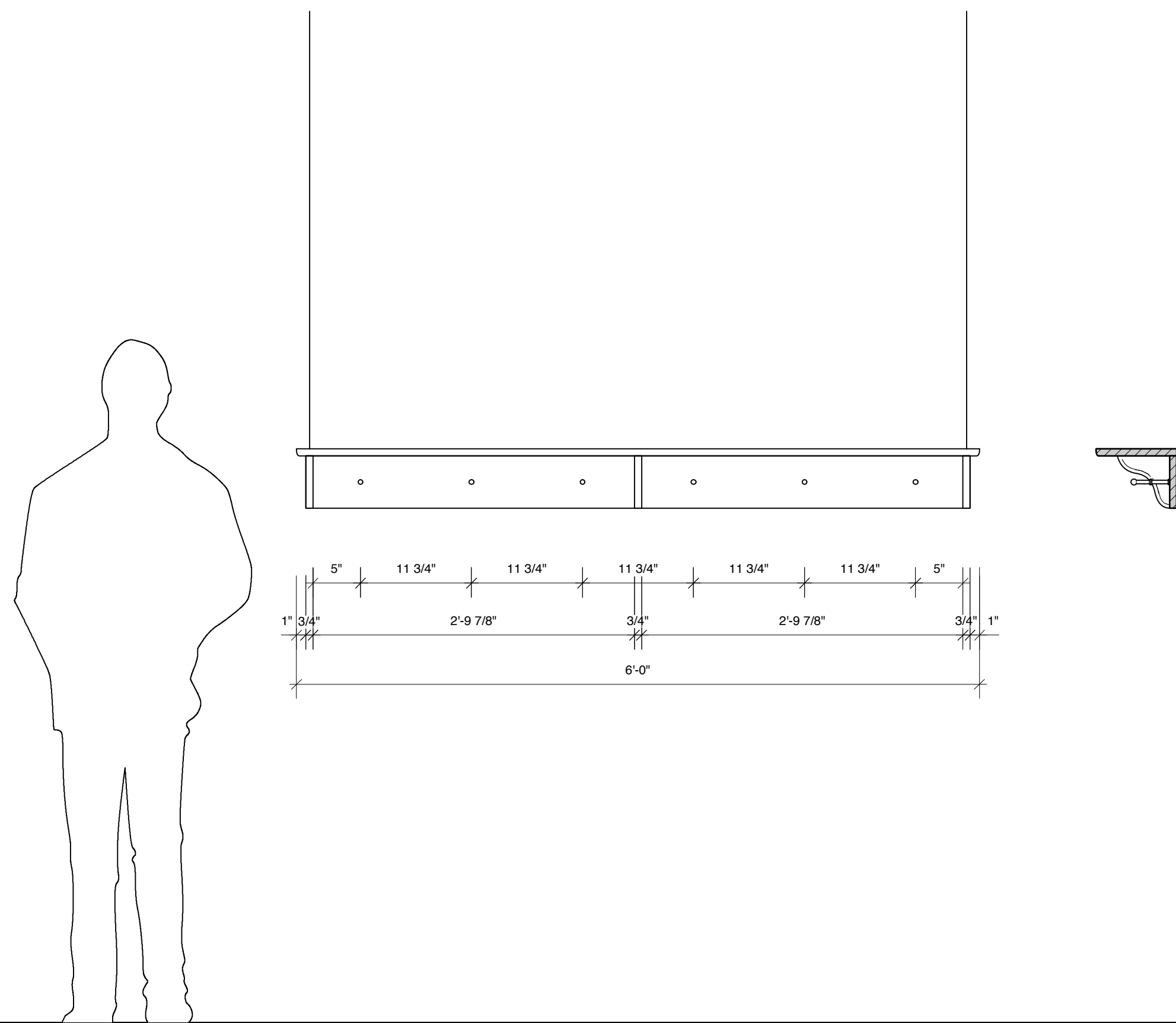

CL SECTION

CENTERLINE SECTION FULL SCALE

RIGGED TO FLY.
DRESSING TBD.

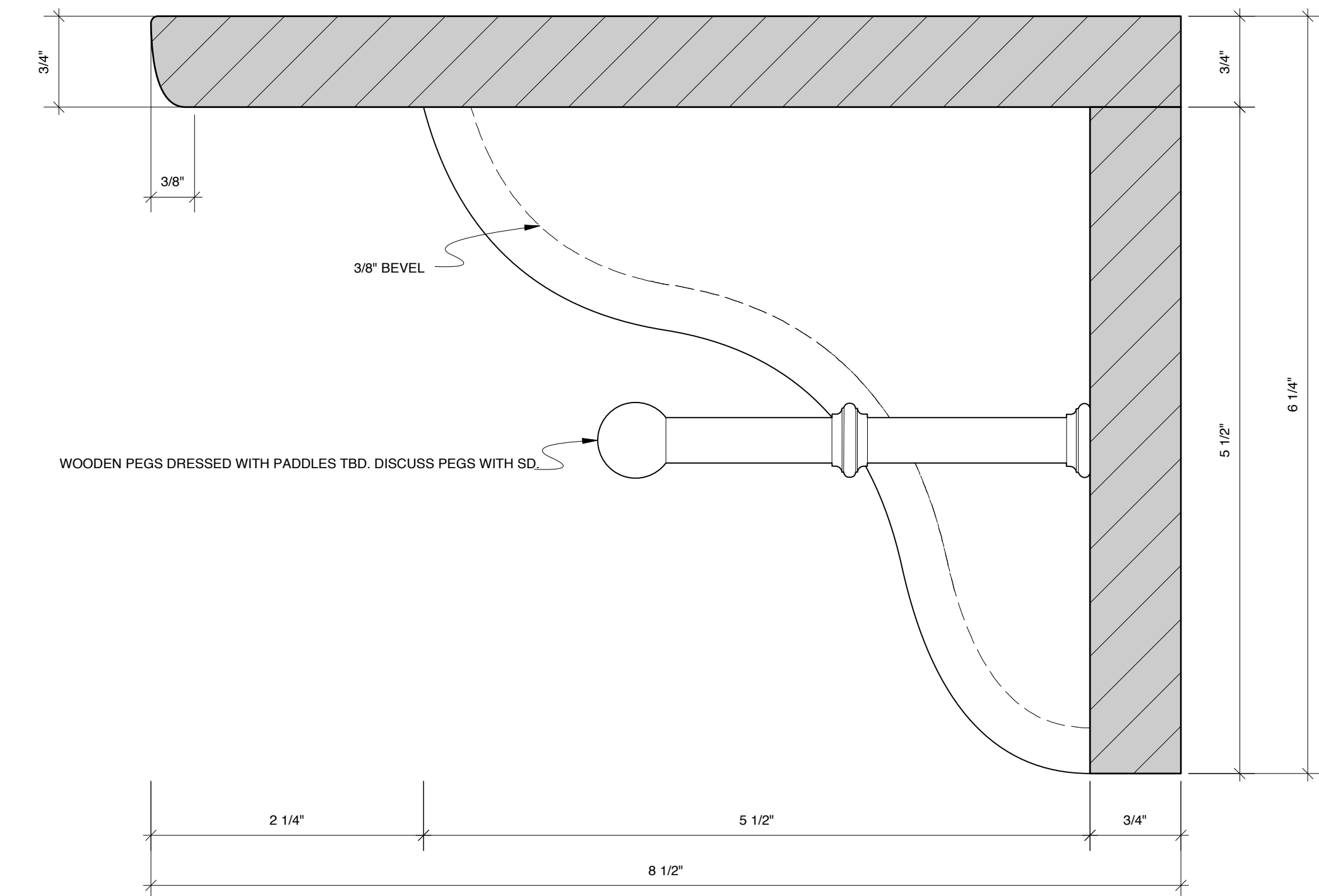

<p>S.D. 3347 SCENIC DESIGNER</p>	FLOWN SHELF UNIT		SHEET 19
	LYSISTRATA JONES by LEWIS FLINN & DOUGLAS CARTER BEANE		
	WALTER KERR THEATER		
	DIRECTED BY DAN KNECHTGES		
	DESIGN BY ALLEN MOYER		
SIGNATURE _____	SCALE: 1" = 1'-0"	DATE: OCTOBER 10, 2011	

SCORE BOARD

RIGGED TO BAND PLATFORM.
CONFIRM RELATION TO LED UNITS WITH ALD.

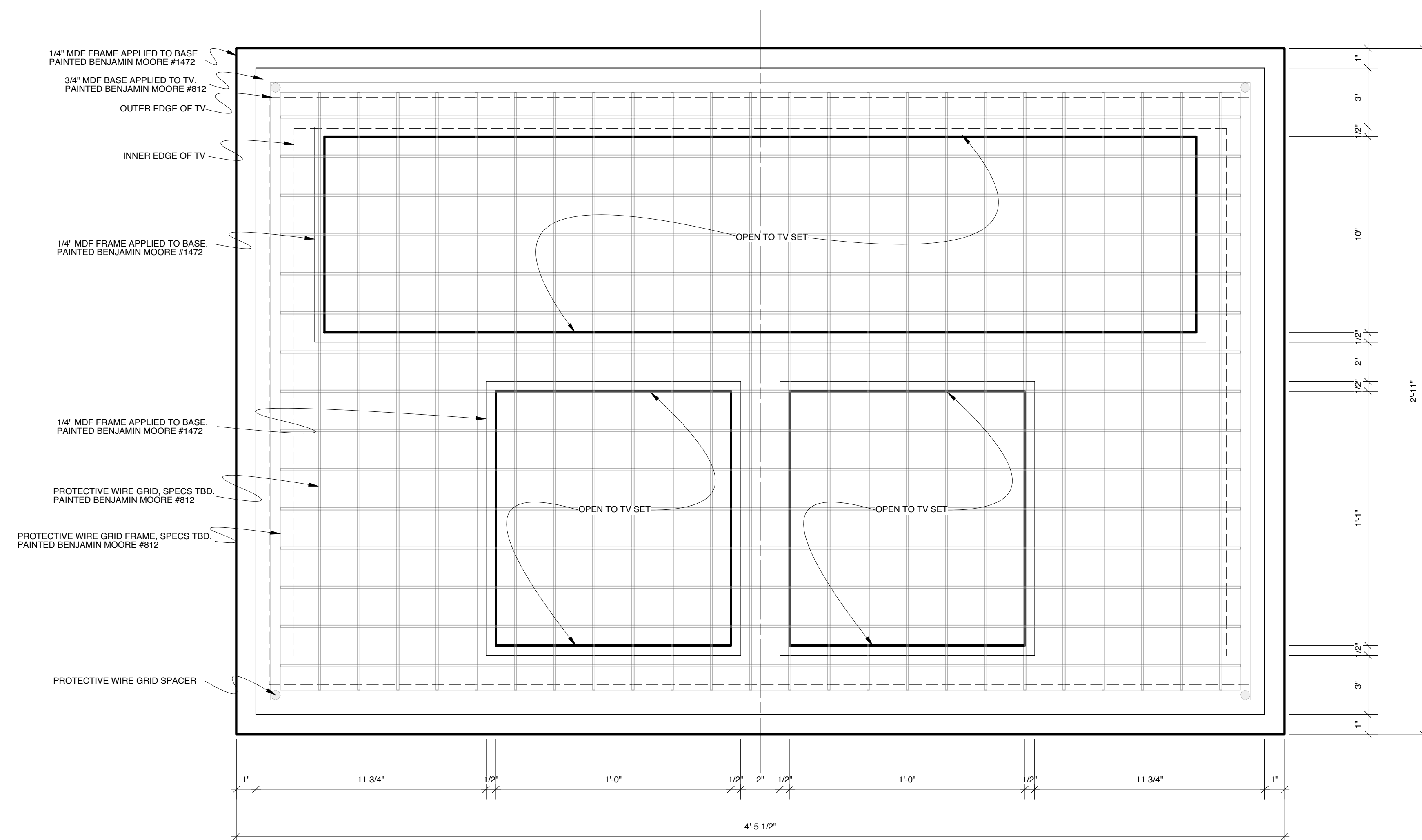

CL SECTION

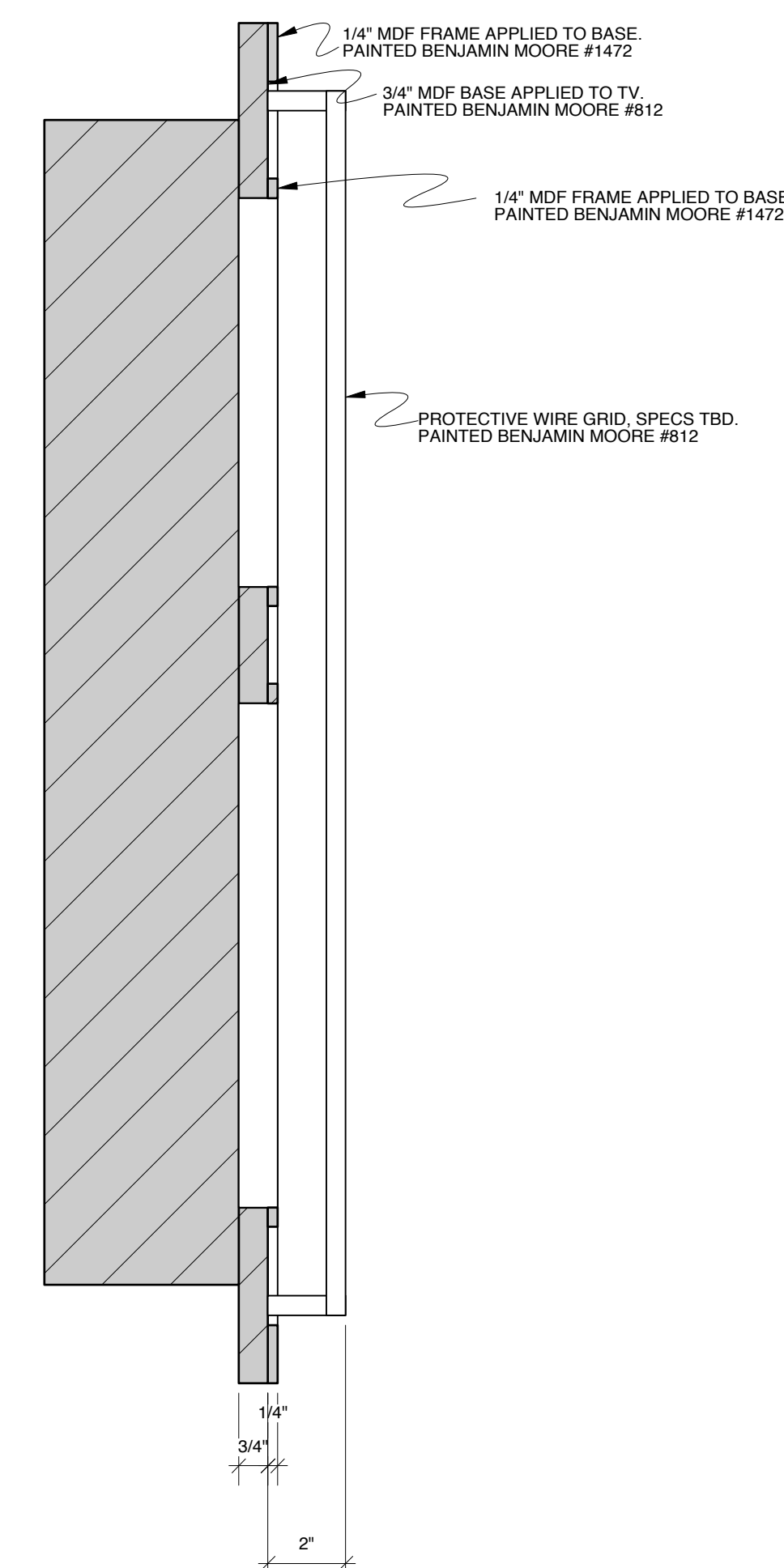

SCORE BOARD

LYSISTRATA JONES by LEWIS FLINN & DOUGLAS CARTER BEANE
WALTER KERR THEATER
DIRECTED BY DAN KNECHTGES
DESIGN BY ALLEN MOYER
SCALE: 3" = 1'-0" DATE: OCTOBER 10, 2011

SHEET

20

DRAWN BY J. COLLINS

DORM ROOM FLAT

RIGGED TO FIT OVER SHELF SIDE OF LOCKER UNIT DURING INTERMISSION.
 FACED WITH ROSEBRAND CINDERBLOCK.
 NON-PRACTICAL DRAWERS.

SECTION

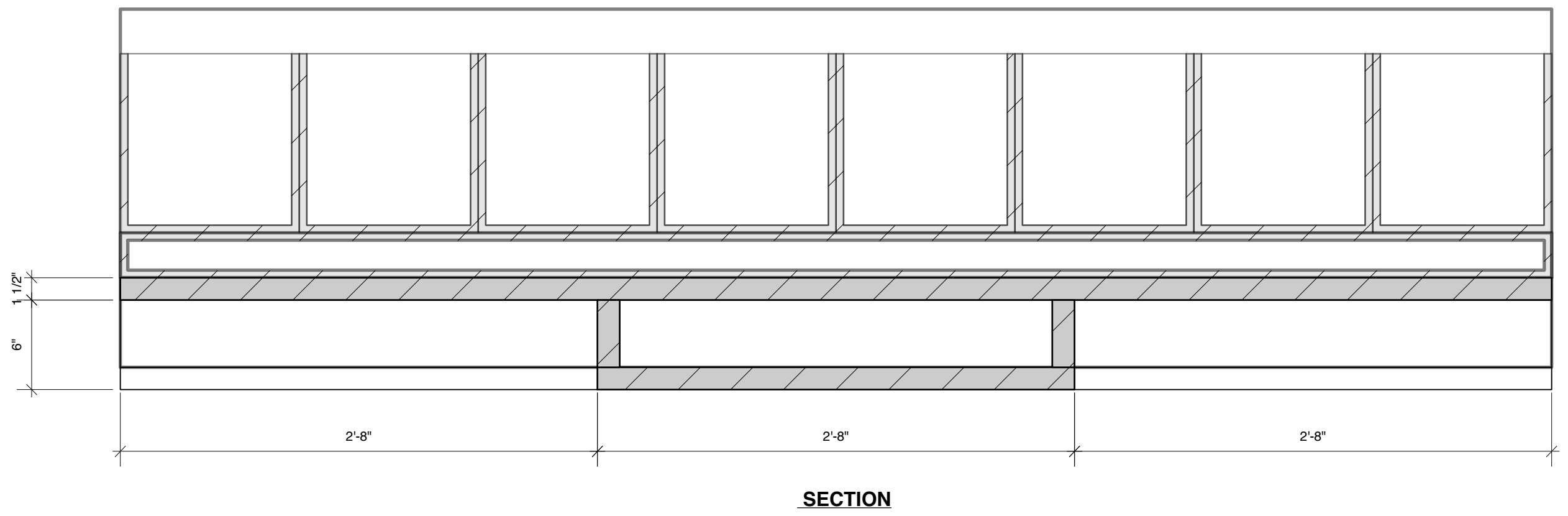
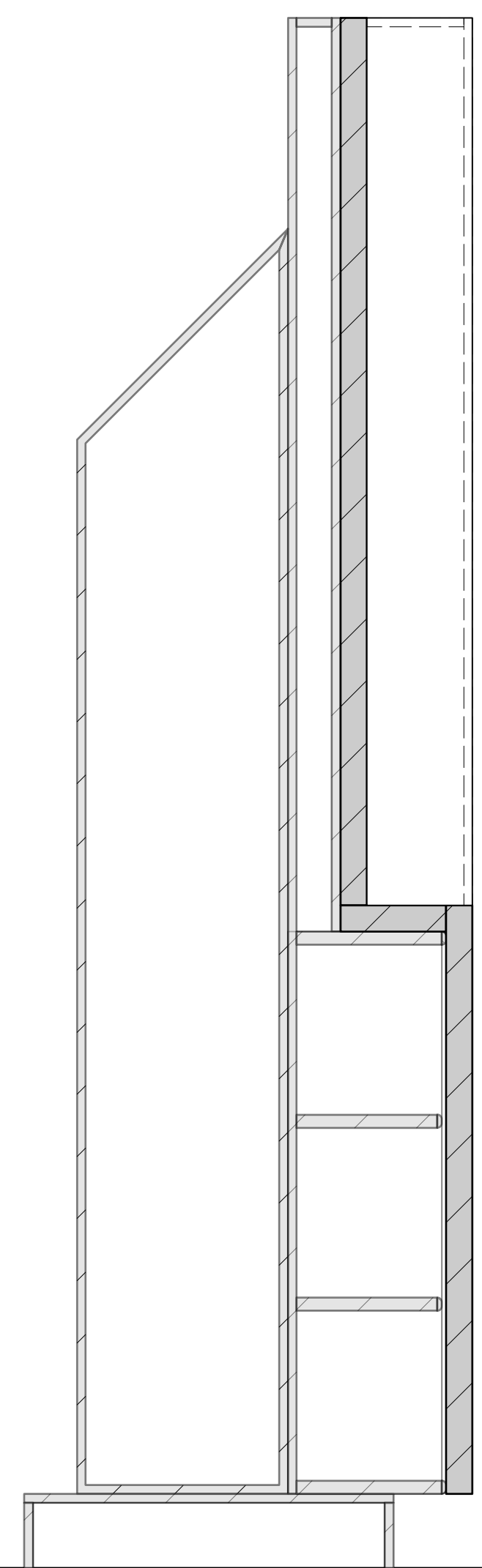
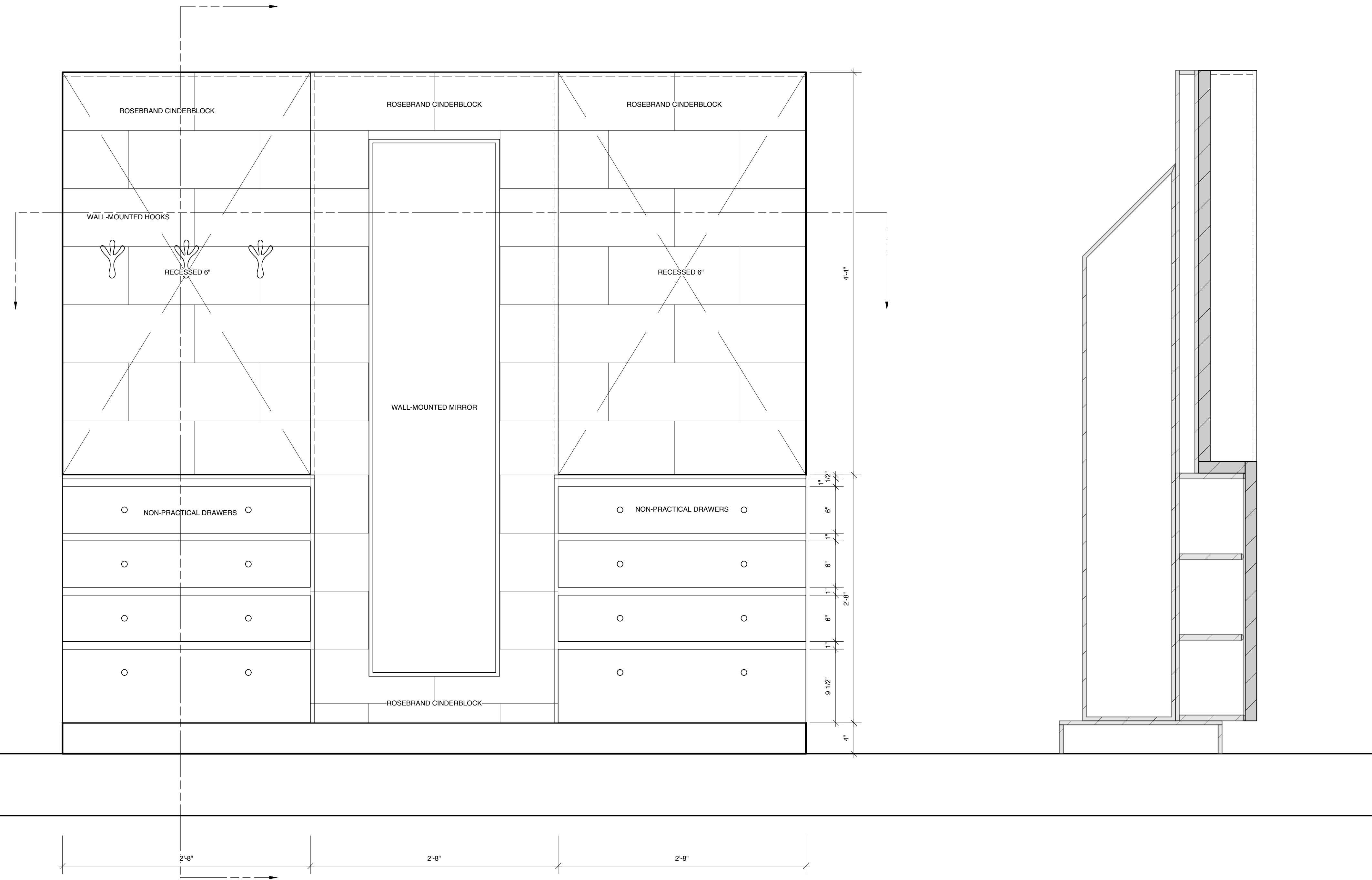

SECTION

<p>S.D. 3347 SCENIC DESIGNER</p>	DORM ROOM FLAT		SHEET <h1 style="font-size: 48px; margin: 0;">21</h1>
	LYSISTRATA JONES <small>by LEWIS FLINN & DOUGLAS CARTER BEANE</small>		
	WALTER KERR THEATER		
	DIRECTED BY DAN KNECHTGES		
	DESIGN BY ALLEN MOYER		
SCALE: 1 1/2" = 1'-0"	DATE: OCTOBER 10, 2011		